



HTLN-GFC-KIT-120

Plug-in Power 120V Connection Kit with End Seal

Installation Instructions

Kit Description

The Heat-Line HTLN-GFC-KIT-120 is a 120V, 15A, plug-in, ground-fault-protected power connection and end seal kit for use with Heat-Line HTLN or 2700 Series 120V heating cables in select watt densities.

This kit ensures compliance with Heat-Line, NEC, and CEC requirements for ground-fault protection of equipment. It includes materials for one power connection and one end seal. All Heat-Line HTLN or 2700 Series heating cables are designed for water-pipe freeze protection applications. Only HTLN or 2700 Series 5W/ft @50F (16 W/m @ 10C) heating cables are approved for both pipe freeze protection and roof and gutter de-icing applications.

For expert technical support call Heat-Line at (800) 584-4944.

Tools Required

- Needle-nose pliers
- Diagonal cutters
- Phillips screwdriver
- Utility knife
- Heat gun
- Crimping pliers
- Lineman's pliers

Additional Materials Required (but not provided)

- Grounded, certified 15-amp, 120-volt receptacle (receptacle must be approved for wet locations if exposed to weather).
- Cable ties, cable guard, downspout hangers, and roof clips may be required for roof and gutter applications.
- Pipe applications may require fiberglass tape, cable ties, foil tape and additional warning labels to complete the installation.

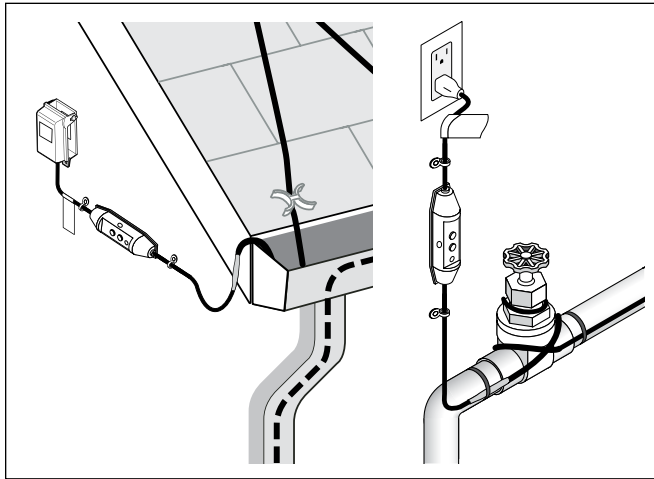

Approvals



Usage W and S
Installation Types A and B USA

Power Connection Kit Parts

Item	Qty	Description
A	1	Plug-in cord 14 AWG, 120V 5-15P with in-line GFC (4' length)
B	1	Uninsulated 10-12 AWG braid crimp
C	2	Uninsulated 14-16 AWG buss wire crimps
D	2	Heat-shrinkable tubes (3/4 inch long x 1/8 inch dia.)
E	2	Cable tie with mounting hole (8 inch)
F	1	Heat-shrinkable tube (8 inch long x 3/4 inch dia.)
G	2	Warning labels for pipe-trace applications (orange)
H	2	Warning labels for roof and gutter applications (yellow)
I	2	Mastic strips (1 1/2 inch long x 1 1/2 inch dia.)
J	1	Silicone form fitting end seal
K	1	Stainless steel mini bolt clamp for end seal
L	1	RTV silicone tube black
M	2	Heat-shrinkable tube (1 1/2 inch long x 1/4 inch dia.)
N	1	Heat-shrinkable tube (1 inch long x 1/2 inch dia.)
O	1	Heat-shrinkable tube (2 inch long x 1/2 inch dia.)

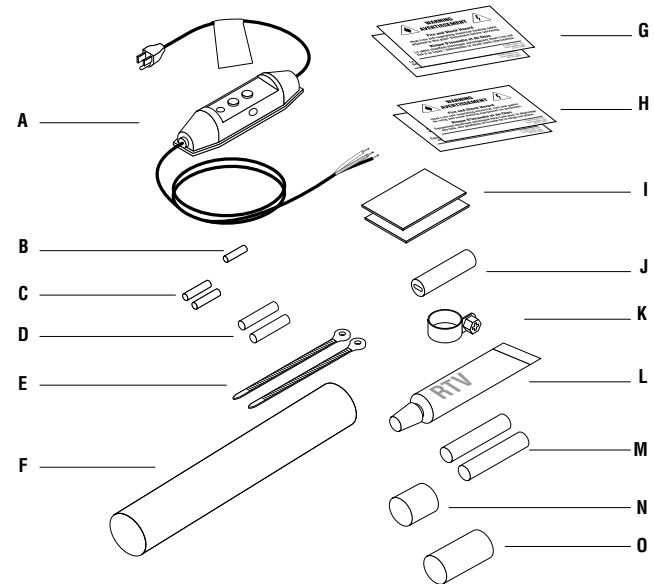

WARNING:

These components are electrical devices. They must be installed correctly to ensure proper operation and to prevent shock or fire.

- Read these rules and instructions carefully. Failure to follow them could result in serious bodily injury and/or property damage.
- Check your local building, plumbing and electrical codes before installing. You must comply with their rules.
- Shock and Fire Hazard. Damaged heating cable or components can cause electrical shock, arcing, and fire. Do not attempt to energize damaged cable or components. Replace them immediately using a new length of heating cable and the appropriate Heat-Line accessories.
- Do not use extension cords.
- For the Heat-Line warranty to be valid, you must comply with all the requirements outlined in these guidelines.
- To minimize the danger of fire from sustained electrical arcing if the heating cable is damaged or improperly installed, and to comply with the requirements of the national electrical codes, ground-fault equipment protection must be used on each heating cable branch circuit.
- Component approvals and performance are based on the use of specified parts only. Do not substitute parts.
- Keep components and heating cable ends dry before and during installation.
- Damaged buss wires can overheat or short. Do not break braid or buss wire strands when scoring the jacket or core.
- Buss wires will short if they contact each other. Keep buss wires separated.
- Heat-damaged components can short. Always use a heat gun over a torch. Avoid heating other components. Replace any damaged parts.
- Use only fire-resistant insulation materials such as fiberglass wrap.
- Leave these installation instructions with the user for future reference.
- For additional installation questions, support, or replacement parts contact Heat-Line at (800) 584-4944.

**HTLN-GFC-KIT-120 DESIGN AND INSTALLATION INFORMATION FOR 120V HEATING CABLE ON PIPES ONLY
(HTLN OR 2700 SERIES 3W/FT, 5W/FT, AND 8W/FT @50°F (10°C))**

Important: You must follow all the requirements outlined in these guidelines for the Heat-Line warranty to be valid and for all appropriate certifications to apply.

All design information provided in these guidelines is based on a "standard" installation with a heating cable fastened to an insulated pipe. For any other applications or methods of installation, contact Heat-Line at (800)584-4944.

HEATING CABLE SELECTION AND DESIGN

Ensure the heating cable being used is suitable and certified for your application.

1. Determine the correct heating cable watt density

Use Table 1 to select heating cables for insulated metal pipes.



Use Table 2 to select heating cables for insulated plastic pipes.

Find your pipe size in the table, then drop down to the line for the lowest air temperature and correct insulation thickness. The shaded box indicates the heating cable to use, and any number represents the feet of cable needed per foot of pipe.

If no number appears in the cell, install a single run of heat trace. If a number does appear in the cell, spiral trace the pipe.

If your spiraling ratio is 2.0, you may use two straight runs at the 4 o'clock and 8 o'clock positions.

Example 1:

Pipe size: 2 in
 Lowest air temp.: -20F (-29C)
 Insulation thickness: 1 in fiberglass
 Metal pipe:  HTLN or 2700 Series 5W/ft
 Plastic pipe:  HTLN or 2700 Series 8W/ft

Example 2:





Pipe size: 2 in
 Lowest air temp.: -40 F(-40C)
 Insulation thickness: 1/2 in fiberglass
 Metal pipe:  HTLN or 2700 Series 8W/ft
 (Use 1.50 feet of heating cable per foot of pipe.)
 Plastic pipe:  HTLN or 2700 Series 8W/ft
 (Use two straight traces at the 4 o'clock and 8 o'clock positions.)

Table 1: For METAL pipes with FIBERGLASS insulation or equivalent (based on 50°F (10°C) maintain temperature)

Key:  = HTLN or 2700 Series 3W/ft  = HTLN or 2700 Series 5W/ft  = HTLN or 2700 Series 8W/ft  = More Insulation Required

Minimum Ambient Air Temp.		Insulation Thickness	Nominal Pipe Size										
			1/2 in	3/4 in	1 in	1 1/4 in	1 1/2 in	2 in	2 1/2 in	3 in	4 in	6 in	
0°F	-18°C	1/2 in										1.25	1.75
		1 in											
		1 1/2 in											
-20°F	-29°C	1/2 in								1.25	1.50	1.75	
		1 in											1.25
		1 1/2 in											
		2 in											
-40°F	-40°C	1/2 in					1.25	1.50	1.75	2.00			
		1 in									1.25	1.75	
		1 1/2 in											1.25
		2 in											

Table 2: For PLASTIC pipes with FIBERGLASS insulation or equivalent (based on 50°F (10°C) maintain temperature)

Key:  = HTLN or 2700 Series 3W/ft  = HTLN or 2700 Series 5W/ft  = HTLN or 2700 Series 8W/ft  = More Insulation Required

Minimum Ambient Air Temp.		Insulation Thickness	Nominal Pipe Size										
			1/2 in	3/4 in	1 in	1 1/4 in	1 1/2 in	2 in	2 1/2 in	3 in	4 in	6 in	
0°F	-18°C	1/2 in								1.25	1.50	2.00	
		1 in											1.25
		1 1/2 in											
-20°F	-29°C	1/2 in				1.25	1.50	1.75	2.00				
		1 in									1.25	1.50	2.00
		1 1/2 in											1.50
		2 in											1.25
-40°F	-40°C	1/2 in				1.25	1.50	1.75	2.00				
		1 in							1.25	1.50	1.75	2.00	
		1 1/2 in										1.25	1.75
		2 in											1.50

Note: Heat loss calculations are based on fiberglass insulation. Adding thicker insulation or using materials with higher insulative values will improve energy efficiency. For details on heat loss with other insulation types, please contact Heat-Line.

2. Calculate the total heating cable length required

$$\text{Length} = A + B + C + D + E + F$$

- A Pipe length x spiraling ratio
- B 4 ft x # gate/globe valves x valve length (ft) x spiraling ratio
- C 2 ft x # ball/butterfly valves x valve length (ft) x spiraling ratio
- D 2 ft x # flanges x pipe diameter (ft) x spiraling ratio
- E 2 ft x # pipe supports x pipe diameter (ft) x spiraling ratio
- F 1 ft for each power connection

= Total heating cable length (ft)

3. Determine the maximum heating cable circuit length allowed.

See Table 3 on the next page. Ensure that your circuits do not exceed the maximum circuit length listed in Table 3. If necessary, use additional shorter circuits.

Example (taken from Example 2 [on metal pipe], page 2):

Pipe length:	40 ft
Spiral ratio:	1.50 (from Table 1, page 2)
Ball valves:	2 (each 0.5 ft long)
Power connections:	1

HTLN or 2700 Series heating cable required:

A Pipe length x spiral ratio	= 40 ft x 1.50	= 60.00 ft
B 0 gate valves	= 0	= 0
C 2 ball valves (0.5 ft each)	= 2 ft x 2 x 0.5 x 1.25	= 2.5
D 0 flanges	= 0	= 0
E 0 pipe supports	= 0	= 0
F 1 power connection	= 1 ft x 1	= 1.0 ft

Total heating cable length required = 64 ft*

* The length is rounded up to the nearest full foot.

HEATING CABLE INSTALLATION

1. Prepare for installation

- Store the heating cable in a clean, dry place.
- Review the HTLN or 2700 Series heating cable design and compare to materials received to verify that the proper heating cable and accessories are as ordered. The heating cable will have the heating cable type and watt density printed on the outer jacket.
- Install only in accessible locations. Do not install behind or through walls, ceilings, or floors, or in any place where the heating cable would be hidden.
- Connect only to properly grounded outlets that have been installed in accordance with all prevailing national and local codes. Outlets must be protected from rain and other water.
- When positioning the heating cable on the pipe, avoid bending it tighter than a 1/2" radius. The heating cable does not bend well on a flat plane. Forcing such a bend may damage the heating cable.

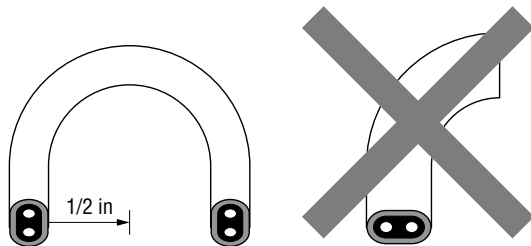

2. Cut the heating cable to length

- Cut the heating cable to the length required. This can be done before or after the cable is fastened to the pipe. Leave a minimum of 1 foot extra heating cable for connection to power. Heat-Line self-regulating heating cable can be cut to length without affecting its heat output per foot.
- Protect the heating cable ends from moisture or mechanical damage if they will be left exposed before connection.

3. Position and attach heating cable to pipe

- Be sure all piping to be traced is dry.
- Install heating cable, using a single run, spiraling, or multiple runs according to the "Heating cable selection and design" section on page 2.
- For single runs, install the heating cable on the lower half of the pipe at the 4 o'clock or 8 o'clock position.
- Be sure to install the additional heating cable required for valves, flanges, etc. as indicated in Step 2 of the "Heating cable selection and design" section.

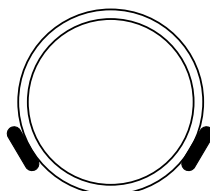

- When the installation calls for spiraling, begin by suspending a loop every 10 feet, as shown in Figure 1. To determine the loop length, obtain the spiral factor from Table 1 or 2 and multiply by 10. For example, if a spiral factor of 1.5 is called for, leave a 15-foot loop of heating cable at every 10-foot section of pipe. Hold the loop in its center and wrap it around the pipe. Even out the distance between spirals by sliding the wraps along the pipe. Use fiberglass tape to secure the center of the loop to the pipe.

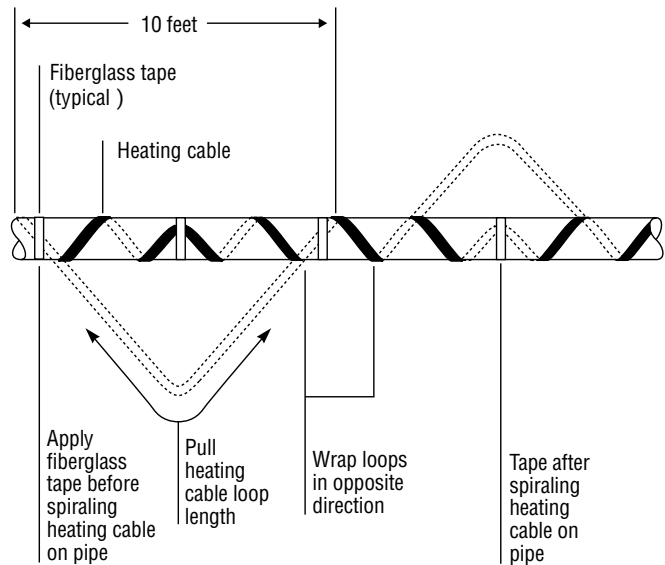
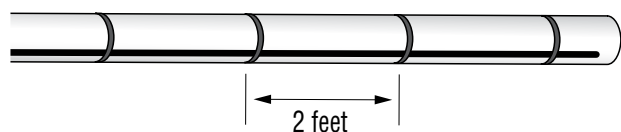

Figure 1. Spiral heat tracing

- Fasten the heating cable securely against the pipe to ensure efficient heat transfer. For best results, consider the addition of aluminum foil tape to further increase the heat transfer over a larger surface area.
- Fasten the heating cable to the pipe at 2-foot intervals using Heat-Line fiberglass tape or nylon cable ties. Do not use vinyl electrical tape, duct tape, metal bands, or wire.



4. Install heating cable end seal and power connection.

- Using a megohmmeter, test each circuit before installing the power connection ground-fault device per the instructions in the “Heating cable testing and maintenance” section.
- Install all end seals and power connection prior to plugging in.
- Follow the HTLN-GFC-KIT-120 kit installation instructions beginning on page 10.
- Use only weatherproof receptacles approved for wet locations when installing the HTLN-GFC-KIT-120 in wet locations.

5. Mark the installation

- This kit includes two labels indicating the presence of electrical heating cable on pipes. One label should be posted on or near the electrical outlet cover, and the other on the circuit breaker. Both labels must be clearly visible. Additional labels may be required to properly label exposed insulation.

6. Check the installation

- Prior to installing thermal insulation, make sure the heating cable is free of mechanical damage (from cuts, clamps, etc.).
- Visually check all end seals and power connections.
- Using a megohmmeter, test each circuit according to the instructions in the “Heating cable testing and maintenance” section (page 4) both before and after installing the thermal insulation.

7. Install insulation

- A reliable heat-tracing system depends on properly installed and weather-proofed thermal insulation.
- Make sure that the type and thickness of the insulation match the specifications in the heating cable selection tables on page 2, and ensure that all pipe work, including valves, joints, and other elements, is fully insulated.
- Verify the HTLN-GFC-KIT-120 ground-fault device is functioning correctly, according to the instructions in the “Heating cable testing and maintenance” section.

ELECTRICAL PROTECTION

To determine the maximum permitted length of the heating cable per circuit for a specific circuit breaker rating, refer to Table 3. Ensure you base your circuit length on the lowest anticipated start-up temperature.

The HTLN-GFC-KIT-120 kit features a built-in 27-mA equipment-protection ground-fault device. This kit provides ground-fault protection for equipment only and does not protect people from electrical shock hazards.

Do not use an extension cord. Plug the unit directly into the outlet.

Note: The NEC and CEC require ground-fault protection for pipe heating cable applications.

Table 3 Maximum Length of Heating Cable on Pipe When Installed with HTLN-GFC-KIT-120

Heating Cable Type	Max Ampacity	Max Length of Heater per Circuit at Start-Up Temperatures		
		50°F / 10°C	0°F / -18°C	-20°F / -29°C
HTLN or 2700 Series 3 W/ft @50°F (10°C) 120V	15 A	300 ft	200 ft	175 ft
HTLN or 2700 Series 5 W/ft @50°F (10°C) 120V	15 A	230 ft	140 ft	125 ft
HTLN or 2700 Series 8 W/ft @50°F (10°C) 120V	15 A	150 ft	95 ft	85 ft

Note: Circuit breaker sizing is based on the CEC and NEC. Maximum circuit lengths are based on start-up load. Average operating amps per foot are dependent upon heating cable temperature.

HEATING CABLE TESTING AND MAINTENANCE

Before installing the ground-fault device, and after installing any end seals, use a 2500-Vdc megohmmeter (Megger) to test the heating cable circuit. Measure the insulation resistance between the heating cable buss wires and the ground braid. If the readings are less than 1000 megohms, inspect the heating cables for damage and verify that the components are correctly installed.

If physical damage is found, the complete circuit must be removed and replaced with new heating cable.

To verify the ground-fault circuit is functioning, test it before each use. Push in the test button. The indicator light must turn off. Then press the reset button. If the light turns back on, the device is functioning correctly. Do not use the device if the indicator light does not turn on when the device is reset or if the indicator light remains on when the test button is pushed.

Test the HTLN-GFC-KIT-120 functionality before each winter season or more often as required by local code.

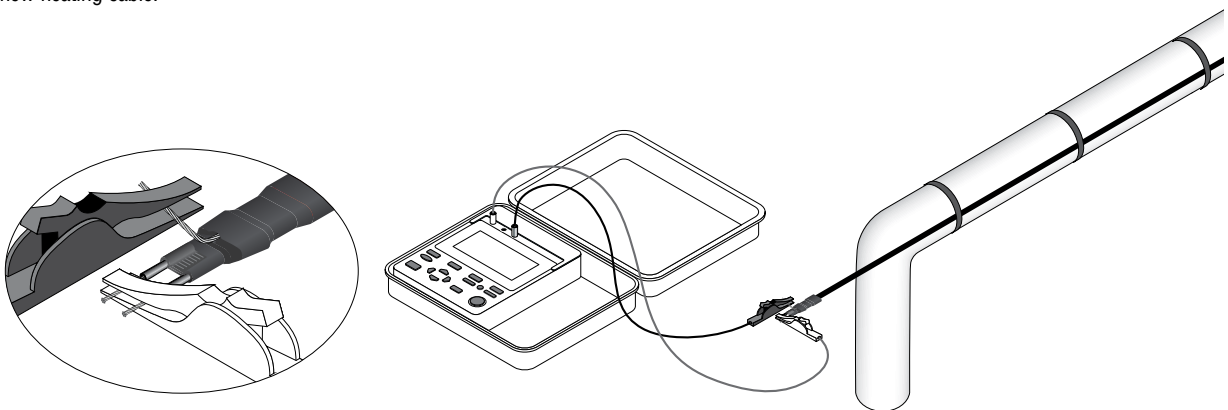
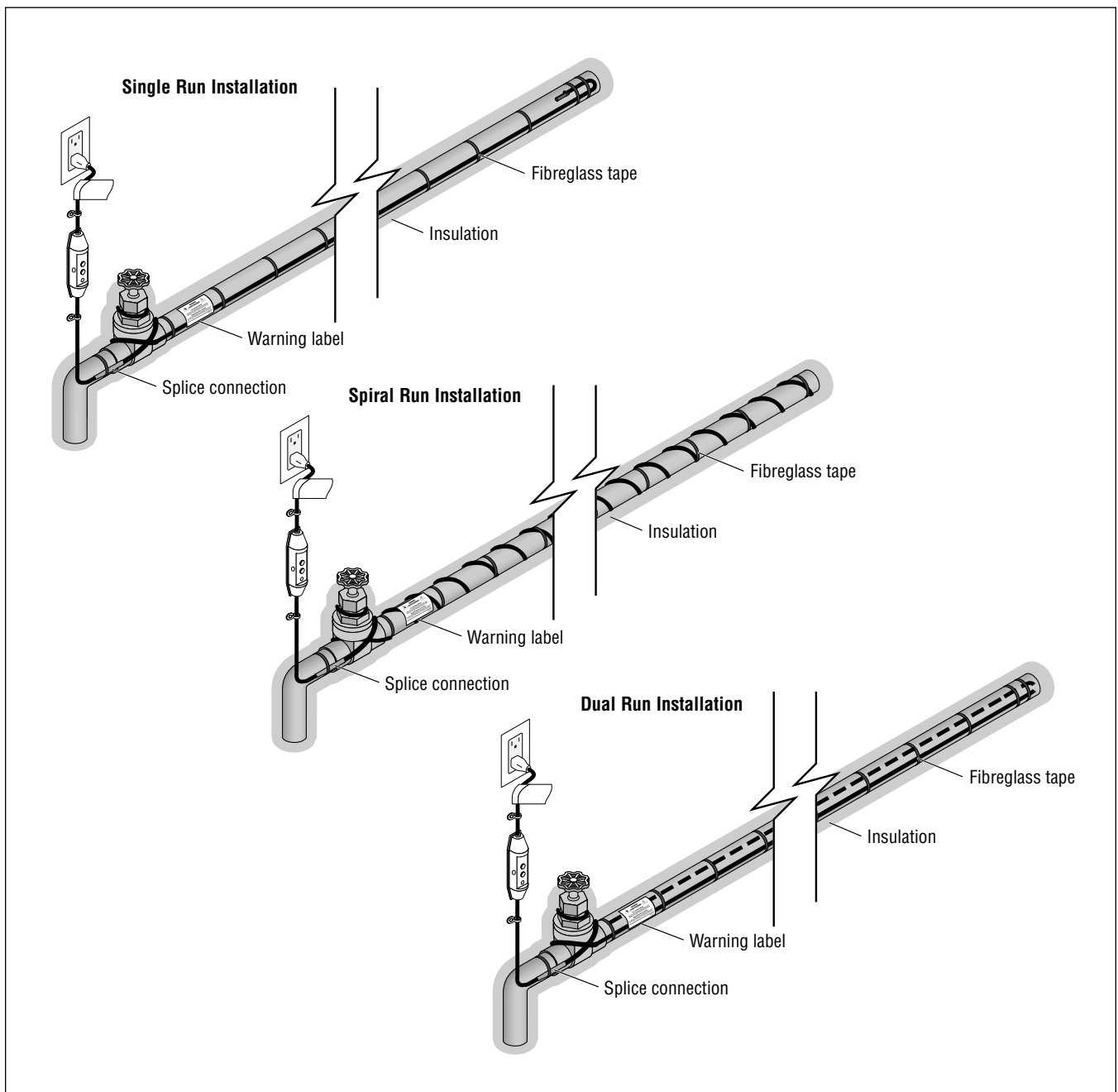

Table 4. Heating Cable Data - HTLN or 2700 Series on Pipe Only When Installed with HTLN-GFC-KIT-120

Heating Cable Type	HTLN-3-120R or 2703-11R00	HTLN-3-120T or 2703-11T00	HTLN-5-120R or 2705-11R00	HTLN-5-120T or 2705-11T00	HTLN-8-120R or 2708-11R00	HTLN-8-120T or 2708-11T00
Voltage (V)	120	120	120	120	120	120
Watt Density at 50°F [10°C] (W/ft)	3	3	5	5	8	8
Outer Jacket Material	Modified Polyolefin Fluoropolymer		Modified Polyolefin Fluoropolymer		Modified Polyolefin Fluoropolymer	
Outer Jacket Colour	Black	Black	Black	Black	Black	Black
Weight Per 100 ft (lbs.)	10	10	10	10	10	10
Minimum Installation Temp. (°F(°C))	0 (-18)	0 (-18)	0 (-18)	0 (-18)	0 (-18)	0 (-18)
Maximum Exposure Temp. (°F(°C))	150°F (65°C)	150°F (65°C)	150°F (65°C)	150°F (65°C)	150°F (65°C)	150°F (65°C)
Environment	Wet or dry locations, ordinary (nonhazardous) areas.		Wet or dry locations, ordinary (nonhazardous) areas.		Wet or dry locations, ordinary (nonhazardous) areas.	



**HTLN-GFC-KIT-120 DESIGN AND INSTALLATION INFORMATION FOR ROOF AND GUTTER DE-ICING ONLY
(HTLN OR 2700 SERIES 5W/FT @50°F (10°C))**

Important: You must follow all the requirements outlined in these guidelines for the Heat-Line warranty to be valid and for all appropriate certifications to apply.

All design information provided in these guidelines is based on a “standard” roof and gutter application. For any other applications or methods of installation, contact Heat-Line at (800)584-4944.

HEATING CABLE DESIGN

Only Heat-Line HTLN or 2700 Series HTLN-5-120R / 2705-11R00 and HTLN-5-120T / 2705-11T00 heating cables are suitable for use with the HTLN-GFC-KIT-120 power connection kit for roof and gutter de-icing applications.

1. Calculate the heating cable length required.

$$\text{Length} = A + B + C + D + E + F$$

- A Roof edge length (ft) x feet of heating cable per foot of roof edge (From Table 5a, 5b, or 5c)
- B Roof edge length (ft) x 0.5*
- C Valley length (ft)**
- D Total gutter length (ft)
- E Total length of all downspouts (ft) + 1 (ft) x number of downspouts***
- F 1 ft for each power connection

= Total heating cable length (ft)

*Roof extension: This length allows the heating cable to extend into the gutter to provide a continuous drain path or extend beyond the roof edge to form a drip loop where no gutters are present.

**For valleys, run the heating cable two thirds of the way up and down the valley. For roof/wall intersections, run the heating cable two thirds of the way up and down the intersection point.

***Depending on the location of the downspout the heating cable may have to run down and back up. Consider this factor when determining the total length of downspouts.

Table 5a. Heat-Line HTLN or 2700 Series Cable Length for Roof and Gutter De-Icing Shingles/Shakes

Eave Overhang	Tracing Width	Tracing Heights	Feet of Heating Cable per Foot of Roof
0	24 inch	12 inch	2.5 feet
12 inch	24 inch	24 inch	3.1 feet
24 inch	24 inch	36 inch	4.2 feet
36 inch	24 inch	48 inch	5.2 feet

Note: Heat-Line recommends heat traced gutters and downspouts to provide a continuous path for melt water.

Table 5b. Heat-Line HTLN or 2700 Series Cable Length for Roof and Gutter De-Icing Standing Seam Metal

Eave Overhang	Tracing Heights	Feet of Heating Cable per Foot of Roof	
		18 inch standing seam spacing (trace every other seam)	24 inch standing seam spacing (trace every other seam)
0	18 inch	2.5 feet	2.0 feet
12 inch	24 inch	2.8 feet	2.4 feet
24 inch	36 inch	3.6 feet	2.9 feet
36 inch	48 inch	4.3 feet	3.6 feet

Note: Heat-Line recommends heat traced gutters and downspouts to provide a continuous path for melt water. For standing seam spacing greater than 24 inches heat trace every seam. Consider a snow retention system or snow guards to prevent sliding ice or snow from damaging the heating cable.

Table 5c. Heat-Line HTLN or 2700 Series Cable Length for Roof and Gutter De-Icing EDGE-CUTTER

Feet of Heating Cable per Foot of Roof
1 foot

Note: Heat-Line recommends heat traced gutters and downspouts to provide a continuous path for melt water.

Example:

Roof Type:	Standard Shingle
Roof edge:	15 ft
Roof overhang:	2 ft
Roof gutter:	15 ft
Total Roof Valleys:	9 ft
Downspout:	10 ft
Power connection:	1 ea

Heating cable required:

A Roof edge	= 15 ft x 4.2 (from Table 5a)	= 63 ft
B Roof extension	= 15 ft x 0.5	= 7.5 ft
C Valley length	= 6 ft	= 6 ft
D Roof gutter	= 15 ft	= 15 ft
E Downspout	= 10 ft + 1 ft	= 11 ft
F Power connection	= 1 ft x 1 ea	= 1 ft

Total heating cable length required = 104 ft*

* The length is rounded up to the nearest full foot. Since this total is less than the 120-foot maximum circuit length (see Table 6), a single circuit is acceptable.

HEATING CABLE INSTALLATION

1. Prepare for installation

- Store the heating cable in a clean, dry place.
- Use only Heat-Line or 2700 series roof and gutter de-icing accessories to ensure a proper installation. These include but are not limited to the below:
 - HTLN-GFC-KIT-120 Plug-in Power 120V Connection Kit with End Seal
 - PLD-RDK Downspout Hangers
 - PLD-RC Roof Clips
 - PLD-CG Cable Guard
 - EDGE-CUTTER Roof De-Icing Flashing
- Carefully plan the routing of the heating cable for roof and gutter de-icing.
- Make certain gutters and downspouts are free of leaves and other debris.

2. Cut the heating cable to length

- When installing the heating cable DO NOT:
 - Pull over sharp edges
 - Use excessive pulling force
 - Kink, crush or stretch the heating cable
 - Walk on the heating cable or install it where it may be walked on
 - Cover the heating cable with any roof materials
 - Attempt to shorten or repair a damaged heating cable
 - Apply any epoxy and or adhesive directly to the heating cable jacket.
- Drip loops are important and commonly used at the point of power connection. The non-heated power supply cord-set must have a drip loop before connecting to or entering the power supply. The drip loop allows flowing or falling water to drip free and not run/ track into electrical enclosure. Drip loops must hang lower than power supply. (See example on page 9.)
- When positioning the heating cable on the roof, avoid bending it tighter than a 1/2" radius. The heating cable does not bend well on a flat plane. Forcing such a bend may damage the heating cable.
- Cut the heating cable to the length required. This can be done before or after the cable is fastened to the roof. Leave a minimum of 1 foot extra heating cable for connection to power. Heat-Line self-regulating heating

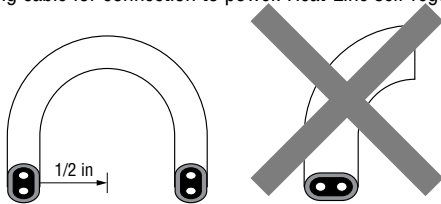

cable can be cut to length without affecting its heat output per foot.

- Protect the heating cable ends from moisture or mechanical damage if they will be left exposed before connection.

2. Position and attach the heating cable.

On shingled roofs

- Loop the heating cable on the overhang area of the roof. This is the part that extends past the building wall. Extend the bottom of each heating cable loop over the roof edge and, using a UV-resistant cable tie, connect the bottom of each loop to the cable running in the gutter to ensure a drainage channel off the roof and into the gutter and downspout. The cable running in the gutter should remain against the bottom of the gutter. If gutters and downspouts are not present, run the heating cable loop over the roof edge approximately 2-3 inches. Extend the top of each heating cable loop approximately 1 foot or 12 inches beyond where the wall joins the roof. For standard shingle installations, Heat-Line recommends 2 feet or 24 inches of clip spacing along the roof edge. For spacing and layout information, see the "Heating cable design" section (Table 5a, 5c).
- Use Heat-Line PLD-RC roof clips to fasten the heating cable to the roof surface. One package of PLD-RC roof clips contains 10 clips for approximately 7 linear feet of roof edge. For flat roofs, the heating cable

can be spaced as needed to create meltwater paths. Use roof clips located at 3-5 foot intervals to secure the cable to the roof. Roof clips

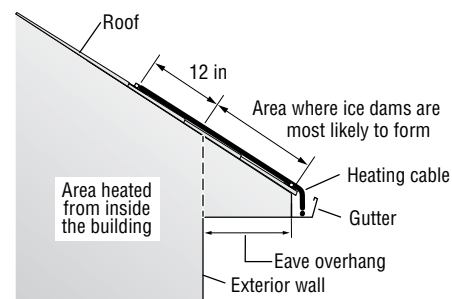
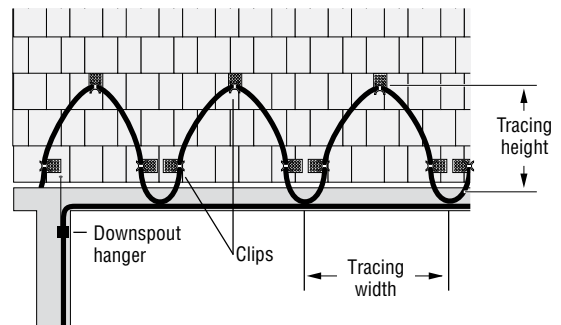

may be attached to a shake, shingle, or metal roofs with nails, screws, and or adhesives. (Refer to Heat-Line PLD-RC installation instructions for more details.) Seal any nail or screw holes, if necessary, before installing the heating cable in the roof clips.

- A barrier (snow retention system or snow guards) can be placed on the roof above the heating cable. This prevents damage to the heating cable from sliding snow or ice. Do not extend the heating cable above the snow fence, as this may lead to sliding ice or snow damaging the heating cable.

On roofs with EDGE-CUTTER

- Proceed to install the EDGE-CUTTER flashing only, DO NOT install channel caps until later in the installation. Once channel caps are installed, they cannot be removed. (Refer to Heat-Line EDGE-CUTTER installation instructions for more specific installation details.) Install the EDGE-CUTTER flashing to the roof substrate by using screws/ nails, flexible adhesives or both. Mounting holes may be installed to accept screws/nails. Do not install fasteners or mounting holes within a 1/2 inch of the flashing edge. Allow 1/4" spacing between flashings for expansion and contraction of the aluminum. Once the flashings are installed, run the heating cable through the channel prior to installing the caps. Make sure there is no debris in the barbed areas on the EDGE-CUTTER flashing or channel cap. Position the channel cap by fitting the top barb first, then snap the channel cap down onto the bottom barb.

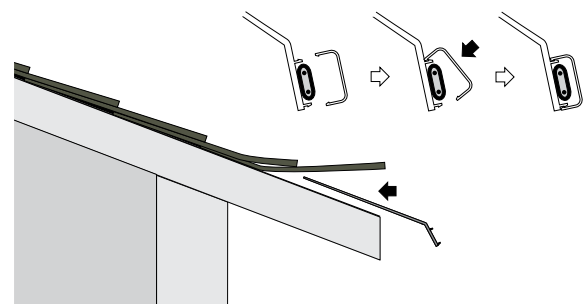

In gutters and downspouts

- Run the heating cable along gutters and into downspouts, ending below the frost line. Fastening the cable to the gutter bottom is not necessary unless the cable is installed in areas of extreme winds. If fastening is required, use Heat-Line PLD-RC roof clips within the gutter. Loop the heating cable in downspouts as required to create a proper melt water path. Depending on the location of the downspout the heating cable may have to run down and back up. Heat-Line recommends protecting the full length of all downspouts. Use the Heat-Line PLD-RDK downspout hanger kit to support all runs of heating cable within the downspout. (Refer to Heat-Line PLD-RDK downspout hanger kit installation instructions for more details.)

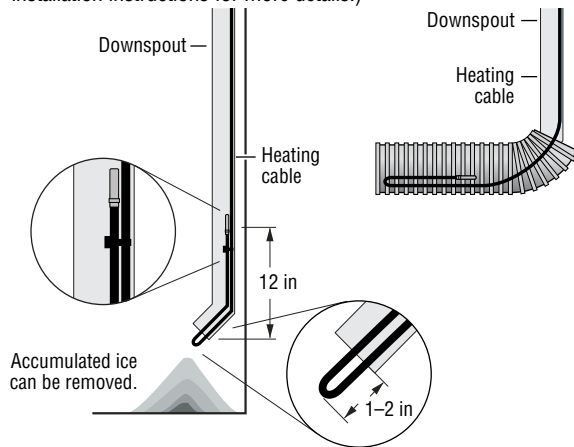

- Use Heat-Line PLD-RDK downspout hangers to protect the heating cable from fraying and damage caused by sharp edges, and to provide strain relief.

- If needed, use Heat-Line PLD-RC roof clips to route heating cable into and out of the gutter in such a way as to prevent abrasion to the cable. Protect all cable that protrudes past the lower opening of the downspout. For further mechanical protection of the heating cable around or over abrasive edges, Heat-Line offers PLD-CG cable guard.

4. Install heating cable end seal and power connection.

- Using a megohmmeter, test each circuit before installing the power connection ground-fault device per the instructions in the “Heating cable testing and maintenance” section.
- Install all end seal and power connection prior to plugging in.
- Follow the HTLN-GFC-KIT-120 kit installation instructions beginning on page 10.
- Use only weatherproof receptacles approved for wet locations when installing the HTLN-GFC-KIT-120 in wet locations or for Roof and Gutter De-Icing applications.

5. Mark the installation

- This kit includes two labels indicating the presence of electric roof and gutter de-icing and snow-melting equipment on the premises. One label should be posted on the electrical outlet cover, and the other on the circuit breaker. Both labels must be clearly visible.

6. Check the installation

- Prior to powering, check to be sure the heating cable is free of mechanical damage (cuts, clamps, etc.).
- Visually inspect all power connections and end seals for proper installation.

7. Test the ground-fault protection

- Verify the HTLN-GFC-KIT-120 ground-fault device is functioning correctly, according to the instructions in the “Heating cable testing and maintenance” section.

ELECTRICAL PROTECTION

To determine the maximum permitted length of the heating cable per circuit for a specific circuit breaker rating, refer to Table 6.

The HTLN-GFC-KIT-120 kit features a built-in 27-mA equipment-protection ground-fault device. This kit provides ground-fault protection for equipment only and does not protect people from electrical shock hazards.

Do not use an extension cord. Plug the unit directly into the outlet.

Note: The NEC and CEC require ground-fault protection for roof and gutter heating cable applications.

Table 6 Maximum Length of Heating Cable for Roof and Gutter De-Icing, Downspouts, and Drains When Installed with HTLN-GFC-KIT-120

Heating Cable Type	Max Ampacity	Maximum Length of Heater
HTLN or 2700 Series 5 W/ft @50°F (10°C) 120V	15 A	120 ft

Note: Circuit breaker sizing is based on the CEC and NEC.

HEATING CABLE TESTING AND MAINTENANCE

Before installing the ground-fault device, and after installing any end seals, use a 2500-Vdc megohmmeter (Megger) to test the heating cable circuit. Measure the insulation resistance between the heating cable buss wires and the ground braid. If the readings are less than 1000 megohms, inspect the heating cables for damage and verify that the components are correctly installed.

If physical damage is found, the complete circuit must be removed and replaced with new heating cable.

To verify the ground-fault circuit is functioning, test it before each use. Push in the test button. The indicator light must turn off. Then press the reset button. If the light turns back on, the device is functioning correctly. Do not use the device if the indicator light does not turn on when the device is reset or if the indicator light remains on when the test button is pushed

Test the HTLN-GFC-KIT-120 functionality before each winter season or more often as required by local code.

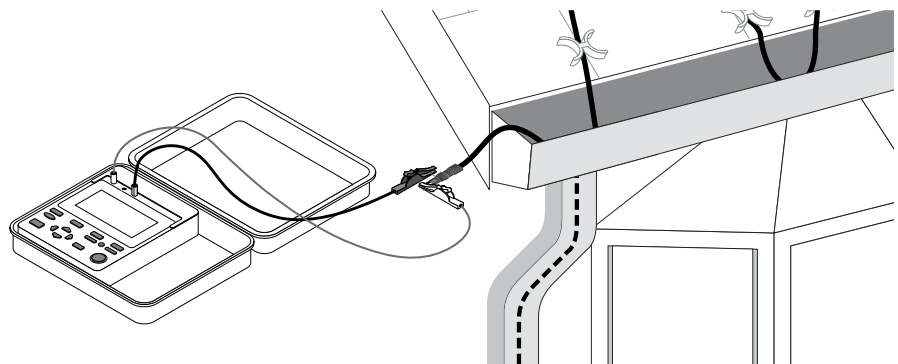
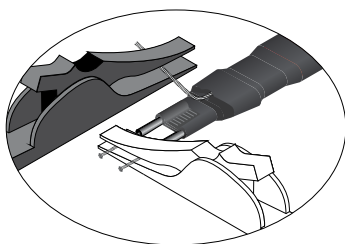

Table 7. Heating Cable Data - HTLN or 2700 Series for Roof and Gutter De-Icing Only When Installed with HTLN-GFC KIT-120

Heating Cable Type	HTLN-5-120R or 2705-11R00	HTLN-5-120T or 2705-11T00
Voltage (V)	120	120
Watt Density at 50°F [10°C] (W/ft)	5	5
Outer Jacket Material	Modified Polyolefin	Fluoropolymer
Outer Jacket Colour	Black	Black
Weight Per 100 ft (lbs.)	10	10
Minimum Installation Temp. (°F(°C))	0 (-18)	0 (-18)
Maximum Exposure Temp. (°F(°C))	150°F (65°C)	150°F (65°C)
Environment	Wet or dry locations, ordinary (nonhazardous) areas.	Wet or dry locations, ordinary (nonhazardous) areas.

Note:

- In all locations, route and secure the heating cable to avoid possible mechanical damage.
- Do not submerge the power connection. It is preferable to rest the power connection in a location that is protected from direct rain/snow.

Shingle/ Shake Roof with Gutters and Downspouts

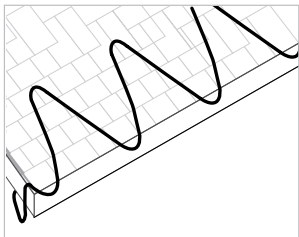
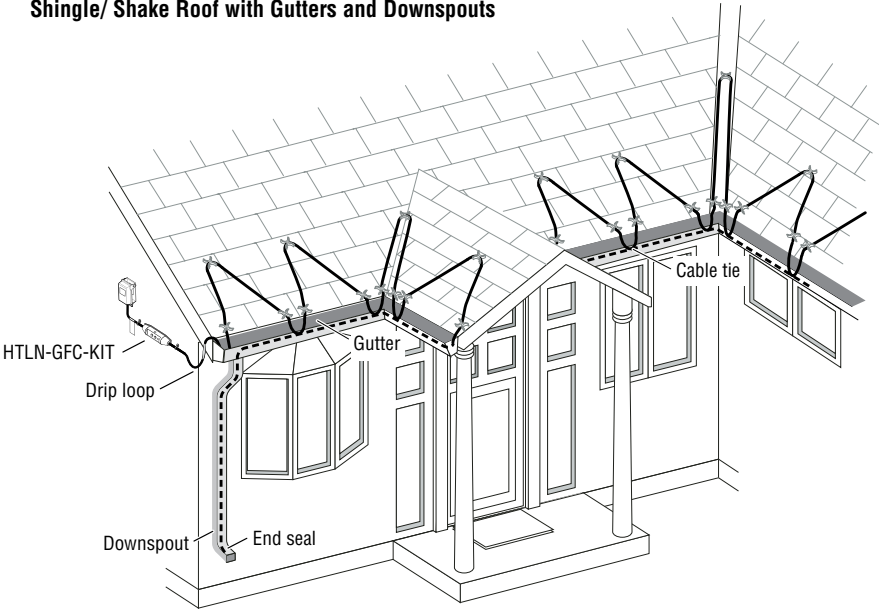

Roofs without Gutters (Roof Extension)

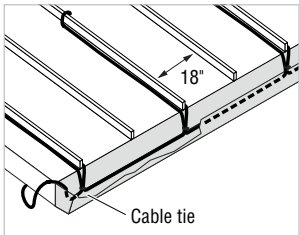

Standing Seam Roof

Roof with EDGE-CUTTER with Gutters and Downspouts

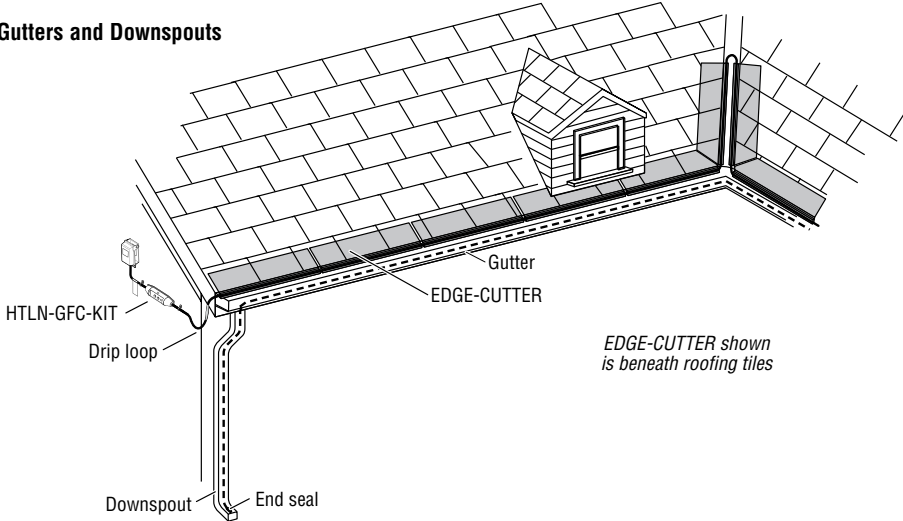

EDGE-CUTTER shown is beneath roofing tiles

Self-Regulating Heating Cable

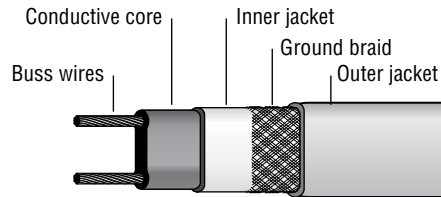

Stripped End of Ground-Fault Protection Device

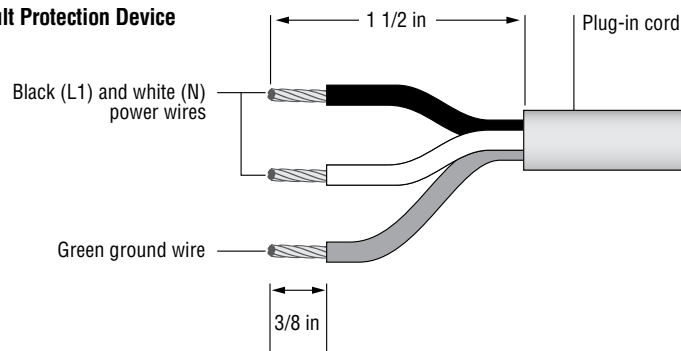

HTLN-GFC-KIT-120 End Seal

1

- Trim the end of heating cable square.
- Strip the outer jacket back 1/2 inch from the end of the heating cable.

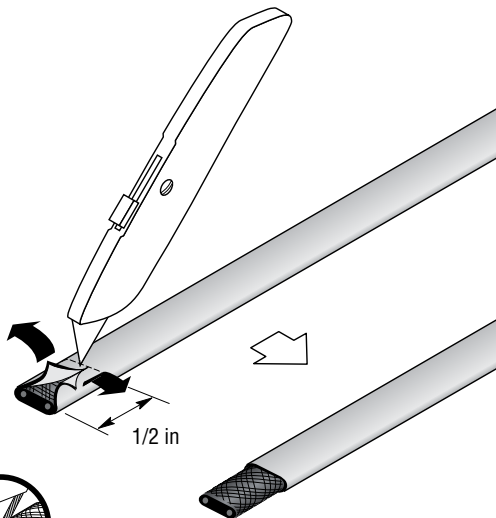

**Do Not Cut or Damage
Ground Braid or Inner Jacket**

2

- Unravel and trim ground braid to within 1/2 inch of the heating cable end. Leaving only a 1/2 inch of the inner jacket exposed.

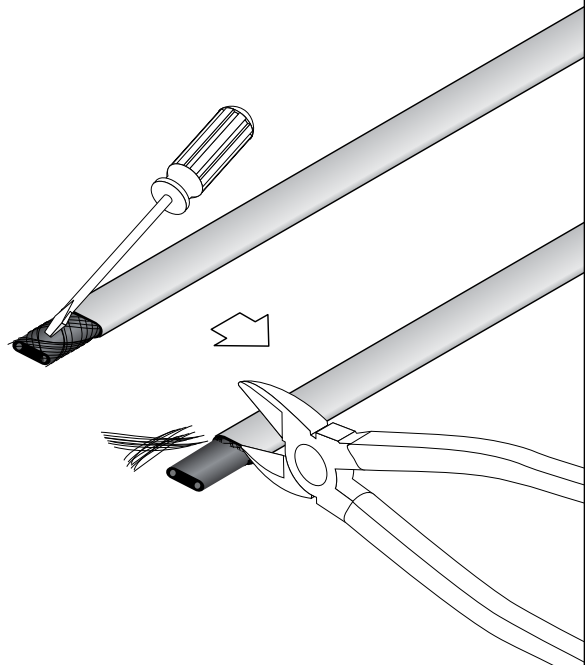

3

- Apply the RTV silicone sealant over 1 inch of the heater end and into the end seal.
- Slide the end seal over the heating cable end. Make sure 1 1/4 inches of the heating cable goes into the end cap, including 3/4 inches of the outer jacket.

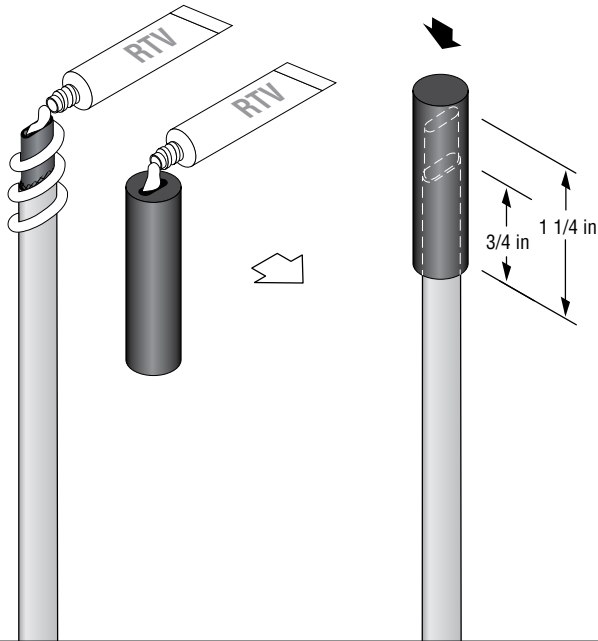

4

- Slide the clamp over the end seal and position it 1/4 inch from the heating cable entrance point. (Note: the screw may have to be completely removed in order to get the clamp over the end seal, and then reinstalled.)
- Tighten the clamp until the end seal deforms and is tightly sealed against the heating cable.

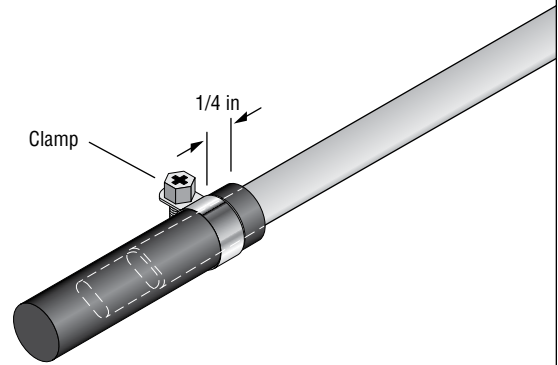

HTLN-GFC-KIT-120 Power Connection

1

- Slide the 8 inch long x 3/4 inch diameter heat shrinkable tube, part F, over the end of the plug-in cord.

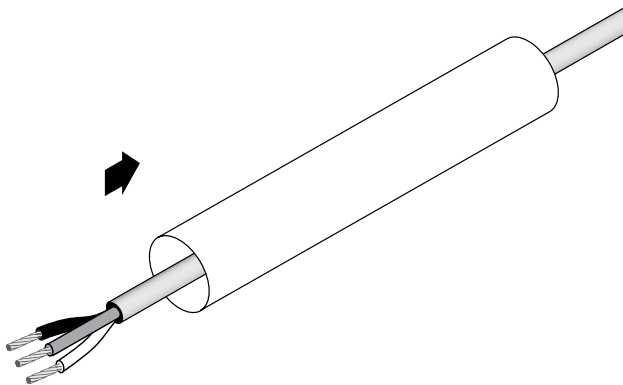

2

- Crimp the 14-16 AWG uninsulated butt crimps, part C, to the stripped ends of the white (N) and black (L1) conductors on the plug-in cord.
- Crimp the 10-12 AWG uninsulated butt crimp, part B, to the stripped end of the green ground conductor on the plug-in cord.

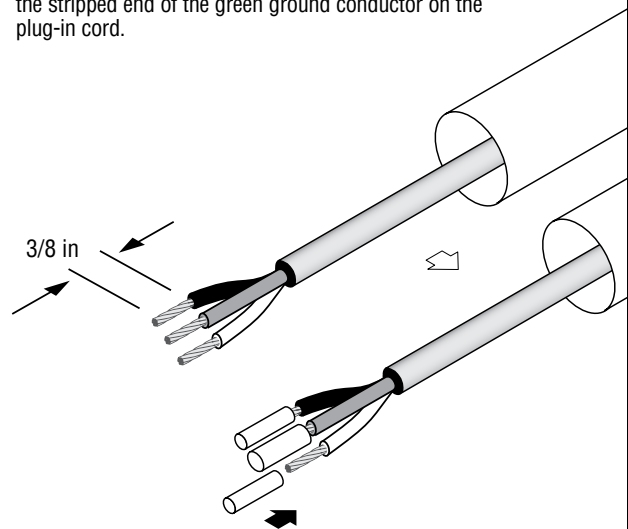

Note: Ensure the correct sized crimp is applied to the correct conductors. The green ground conductor requires the larger 10-12 AWG crimp, part B.

3

- Slide the 1 1/2 inch long x 1/4 inch diameter heat shrinkable tubes, parts M, over the white (N) and black (L1) conductors of the plug-in cord.

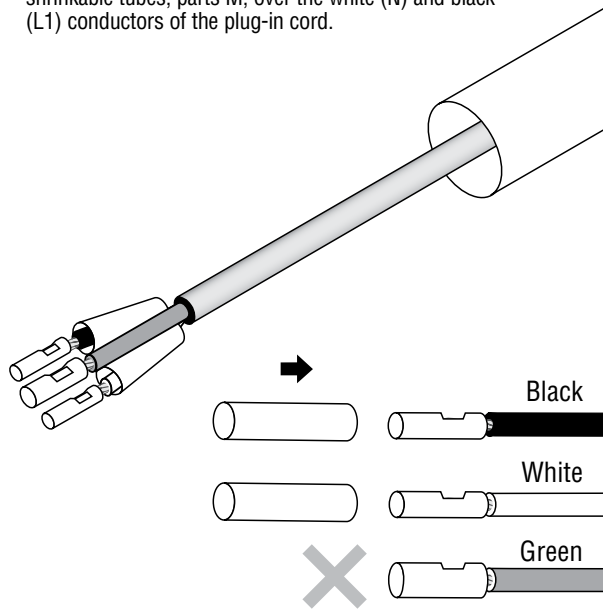

Note: The green ground conductor does not require a heat shrinkable tube.

4

- Identify the power connection end of the heating cable and trim it square.
- Measure 2 inches from the end of the heating cable. Lightly score around and down the outer jacket. Be careful not to cut too deeply.
- After scoring, gently bend the cable at the scored line to help the jacket separate. Peel away and remove the outer jacket as shown.

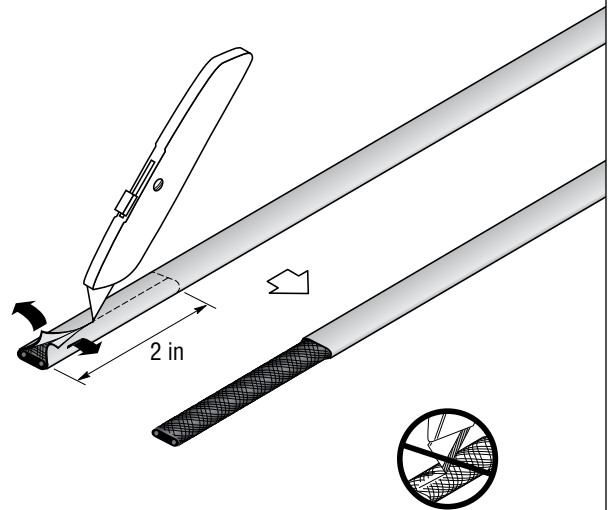

Do Not Cut or Damage Ground Braid or Inner Jacket

5

- Unravel the ground braid to expose the inner jacket.
- Twist the ground braid into a pigtail. Trim the pigtail to remove the tapered end and ensure it is flush with the end of the heating cable.

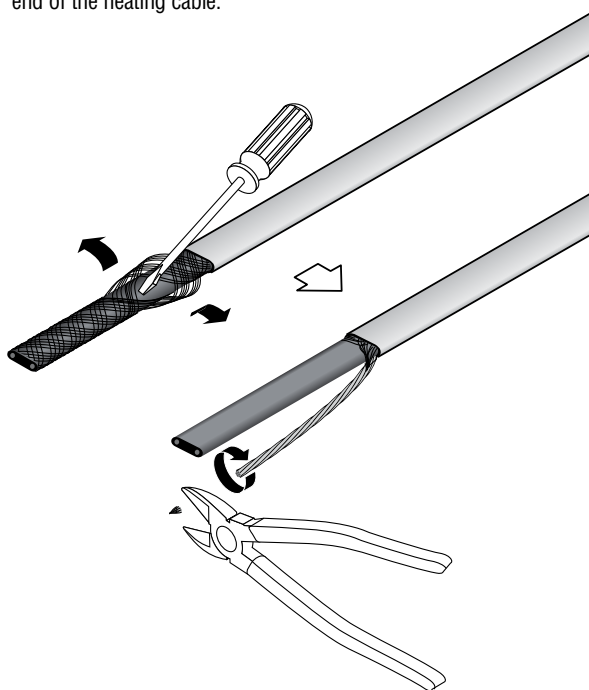

6

- Measure 1 1/4 inches from the end of the heating cable. Lightly score around and down the inner jacket. Be careful not to cut too deeply.
- After scoring, gently bend the cable at the scored line to help the jacket separate. Peel away and remove the inner jacket as shown.
- Ensure that 3/4 inches of the inner jacket remains, covering the conductive core.

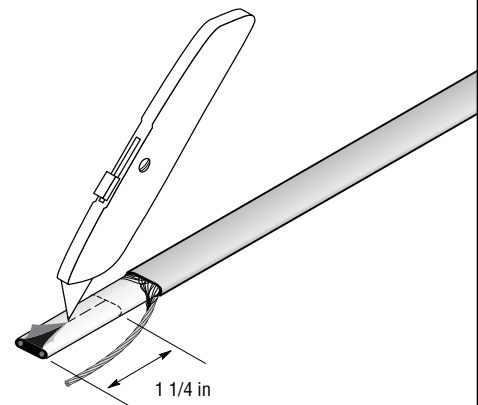

Do Not Cut or Damage Buss Wires

7

- Notch the center conductive core between the buss wires and pull the buss wires away from the core for 1 1/4 inches. Be cautious not to go too deep and cut into or tear on the buss wires.

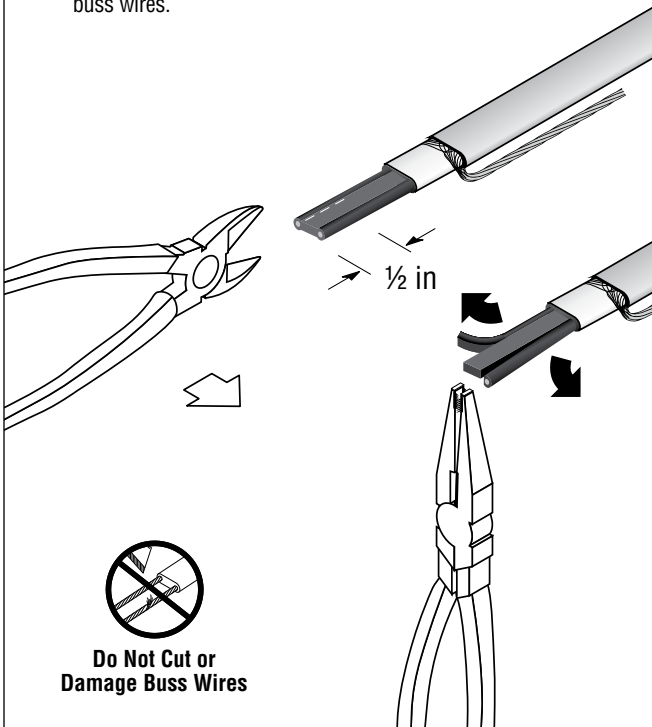

8

- Score the inner conductive core between the buss wires close to the inner jacket.
- After scoring, gently bend and break away the core material. Peel away and remove any core material remaining on the buss wires.
- If required, re-twist buss wires.

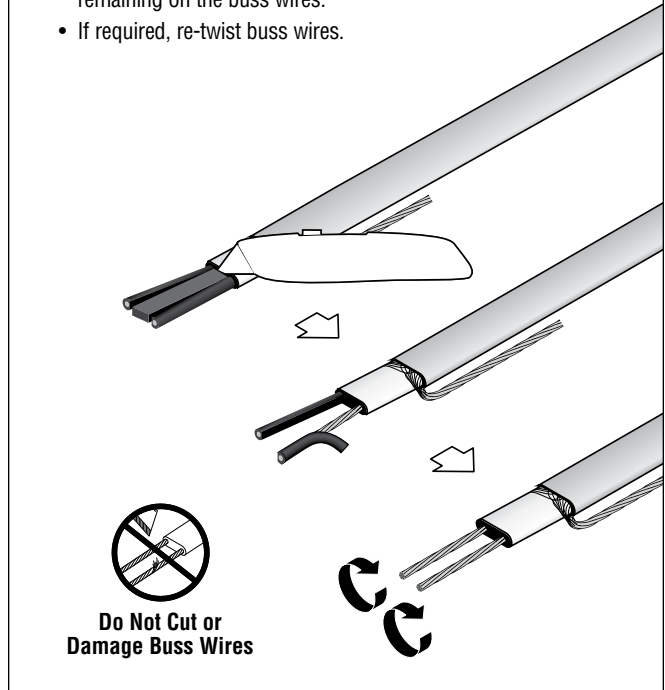

9

- Slide the 1 inch long x 1/8 inch diameter heat shrinkable tubes, parts D, over the buss wires.
- Shrink the heat shrinkable tube into place while moving the heat source side to side. Ensure that the tubes stay tightly against the remaining core and inner jacket.

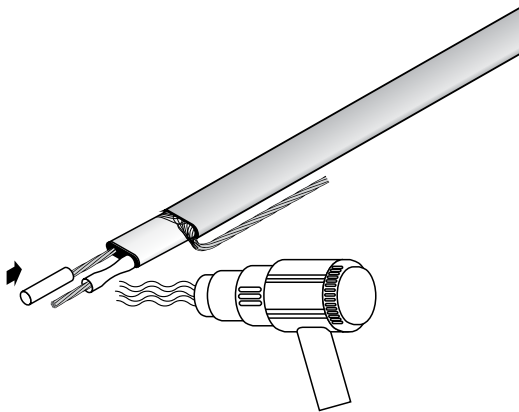

10

- Slide the 1-inch long by 1/2-inch diameter heat shrinkable tube (part N) over the buss wires, ensuring it extends 1/2 inch onto the inner jacket.
- Shrink the heat shrinkable tube into place while moving the heat source side to side. Ensure that the tubes remains in place as heat is applied.
- Immediately after shrinking, pinch between the two buss wires with needle-nose pliers and hold in place for at least five seconds to create a seal and buss wire separation.

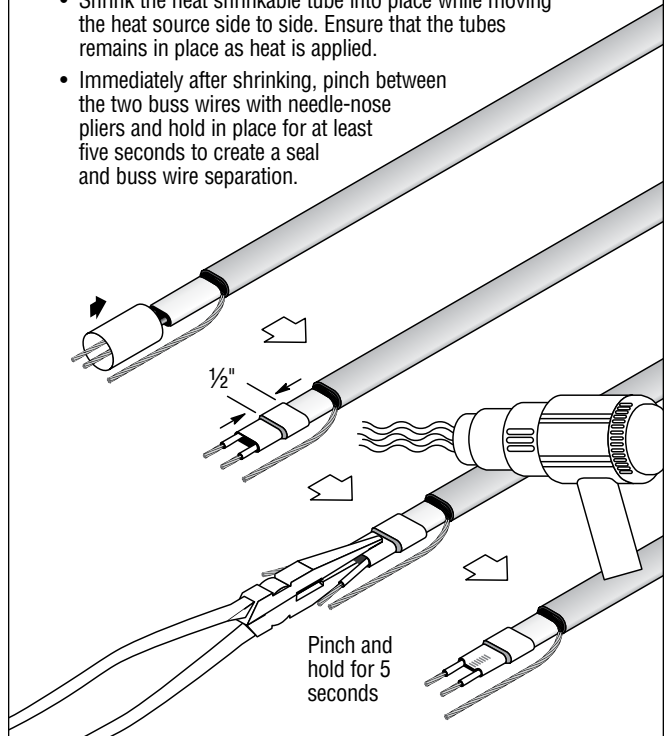

11

- Measure 3 1/4 inches from the end of the buss wires. Slide the 2 inch long x 1/2 inch diameter heat shrinkable tube, part O, over the buss wires, positioning it up to the 3 1/4 inch mark.
- Shrink the heat shrinkable tube into place while moving the heat source side to side. Ensure that the tube remains in place as heat is applied.
- Immediately after shrinking, pinch between the two buss wires with needle-nose pliers and hold in place for at least five seconds to ensure previous seal remains complete.

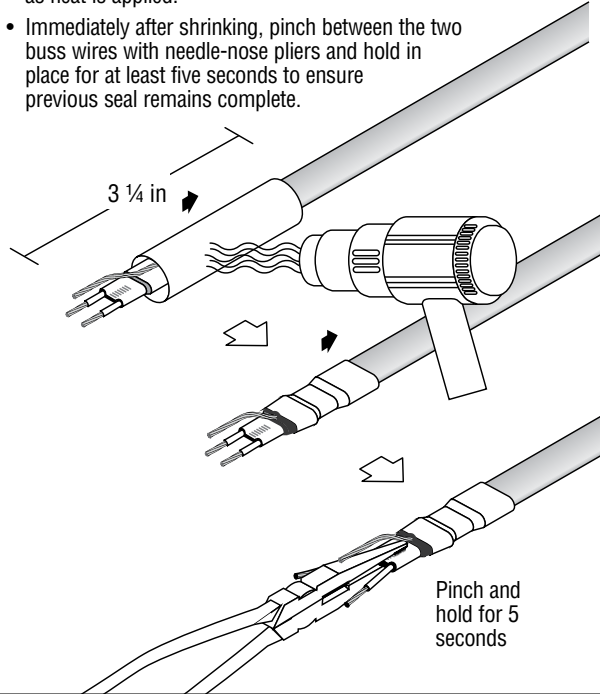

12

- Trim the buss wires to 3/8 inch, ensuring each wire is of equal length and cut squarely.

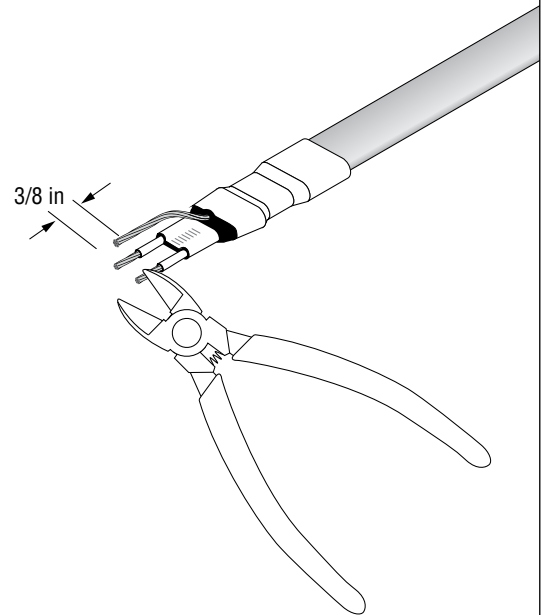

13

- Before installing the ground-fault device, and after installing any end seals, use a 2500-Vdc megohmmeter (Megger) to test the heating cable circuit.
- Measure the insulation resistance between the heating cable buss wires and the ground braid.
- If the readings are less than 1000 megohms, inspect the heating cables for damage and verify that the components are correctly installed.

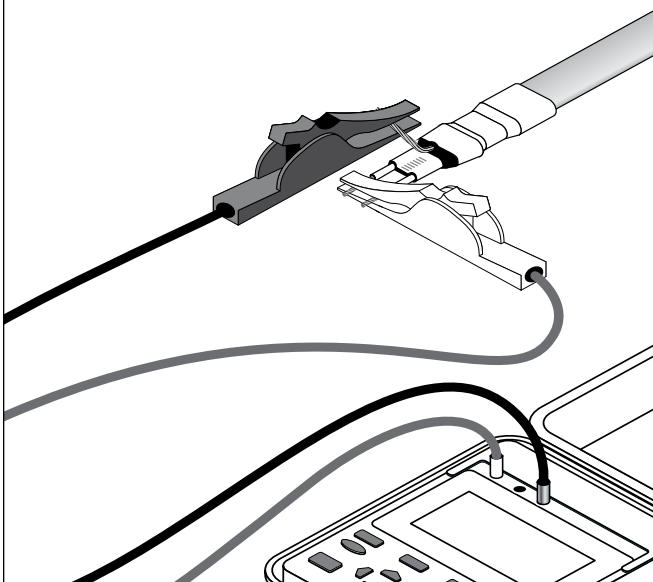

14

- Line up the green ground wire with the heating cable ground braid, and the black (L1) and white (N) wires with the heating cable buss wires.
- The heating cable is not polarity specific. The black (L1) and white (N) wires can connect to either buss wire.

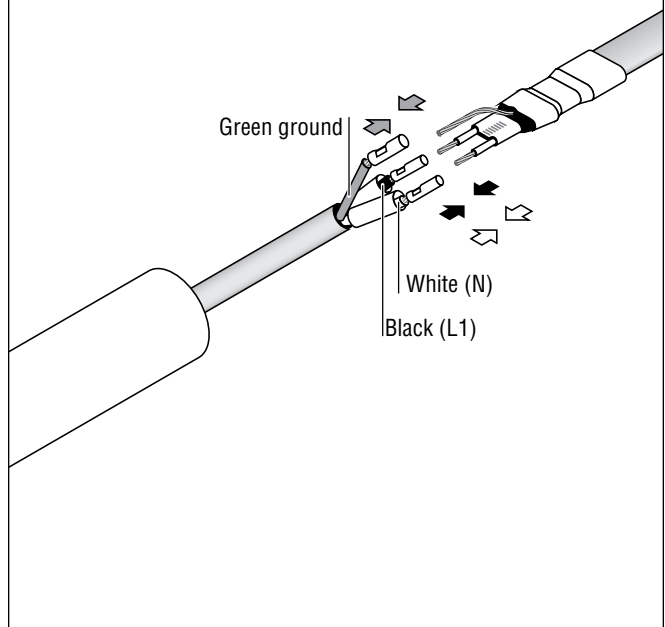

15

- Complete the crimping process by crimping the plug-in power cord to the heating cable buss wires and ground braid.
- Make sure the crimps are securely connected by gently pulling on them to verify their strength.

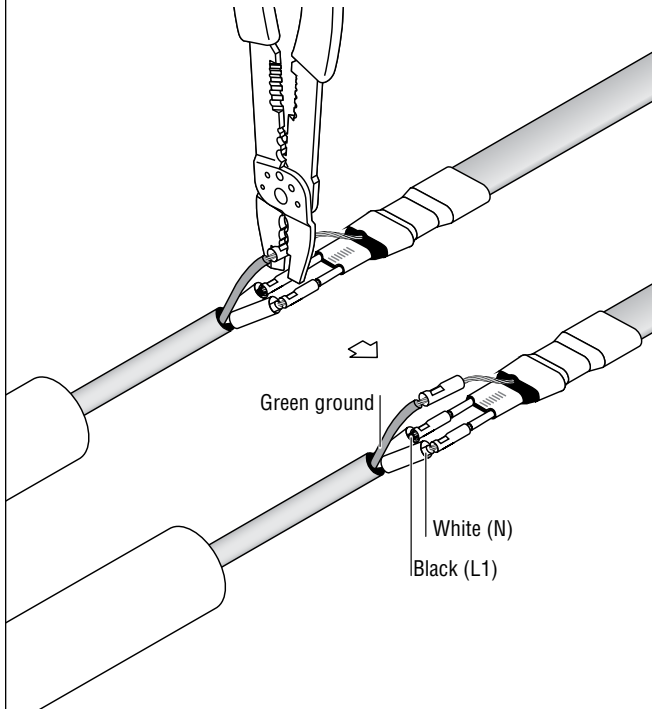

16

- Slide the 1 1/2 inch long x 1/4 inch diameter heat shrinkable tubes, parts M, down the white (N) and black (L1) conductors until they pass over and are centered on the crimps.
- Shrink the heat shrinkable tubes into place while moving the heat source side to side. Ensure that the tubes remain in place as heat is applied.
- Watch for the rings of adhesive to appear on both ends of the tubes.

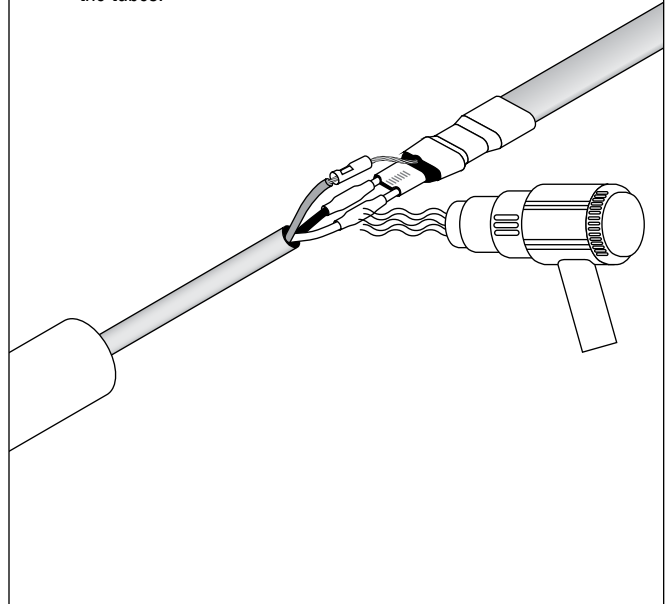

17

- Remove the release paper backing from the mastic, parts I.
- Center and wrap one strip of mastic around the white conductor crimp. Repeat the same process by wrapping the second mastic strip around the black conductor crimp.
- Once applied, squeeze the two rolls of mastic together.

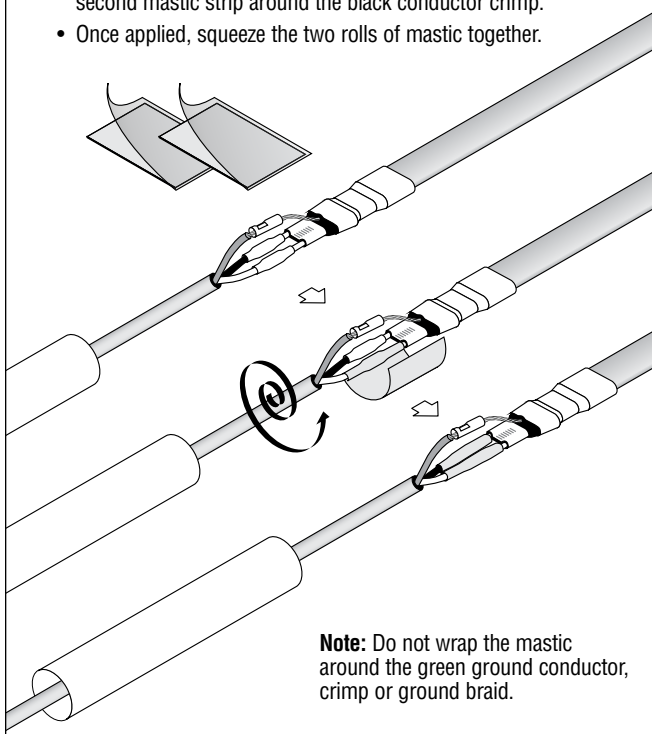

18

- Center the 8 inch long x 3/4 inch diameter heat-shrinkable tube over the butt splice power connection.
- Make sure that the heat-shrinkable tube extends over the heating cable and plug-in cord equivalently.
- Shrink the tube completely. Start at the middle and work toward each end. Make sure not to trap air within the connection. It is important to keep heating after the tube has shrunk to completely melt the adhesive inside tube. Watch for the rings of adhesive to appear on both ends of the tube.
- Total heating time should be approximately 3 minutes.

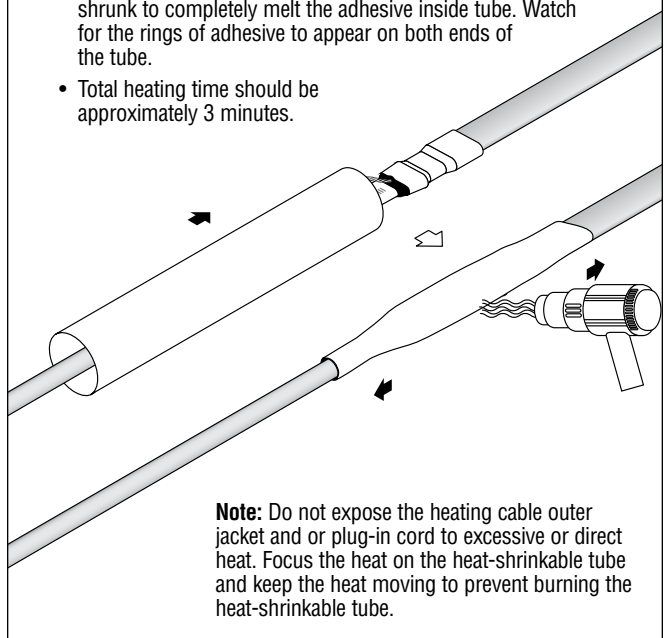

Securing the Ground-Fault Device

1A For Pipe Freeze Protection

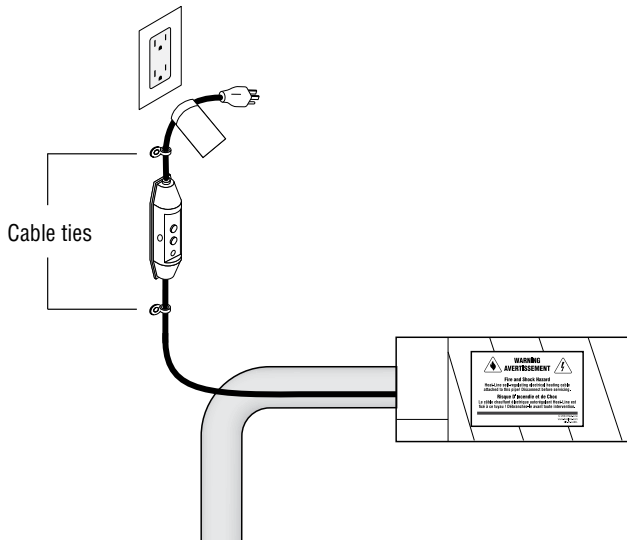

- To prevent damage to the ground-fault equipment protection device and ensure strain relief, use cable ties to secure the device to the wall near the receptacle, taking care not to damage either the cord or the ground-fault unit.

Note: Pipe must be fully insulated.

2A For Roof and Gutter

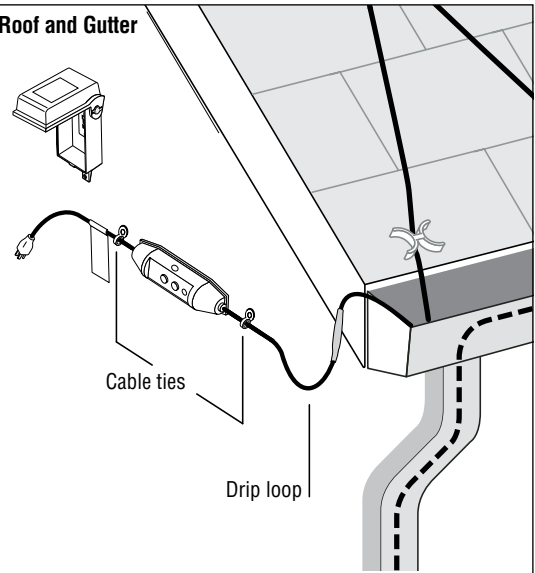

- To prevent damage to the ground-fault equipment protection device and to provide strain relief, use cable ties to secure the device to the wall near the receptacle.
- Include a drip loop as shown to ensure any melt water can drain off roof
- It is preferable to place the ground fault in a location that is protected from direct rain/snow.

1B For Pipe Freeze Protection

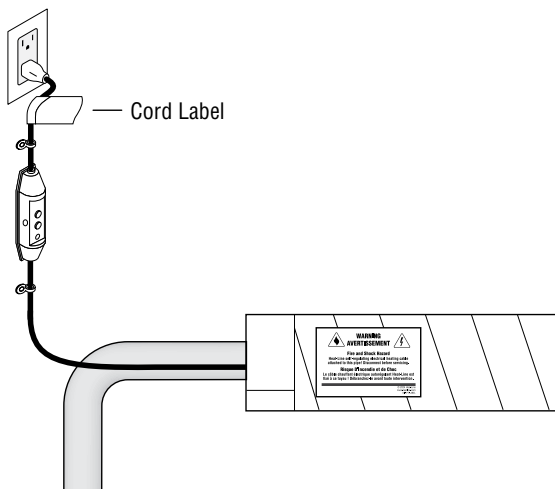

- Plug the heating cable into a 15-A, 120-Vac grounded outlet.
- Make sure that:
 - Cord label is readily visible.
 - Indicator light on the ground-fault equipment protection device is on.
 - Receptacle is properly weatherproofed (if outdoors).
 - Ground fault equipment protection device and power connection splice will not be submerged.

Note: Pipe must be fully insulated

2B For Roof and Gutter

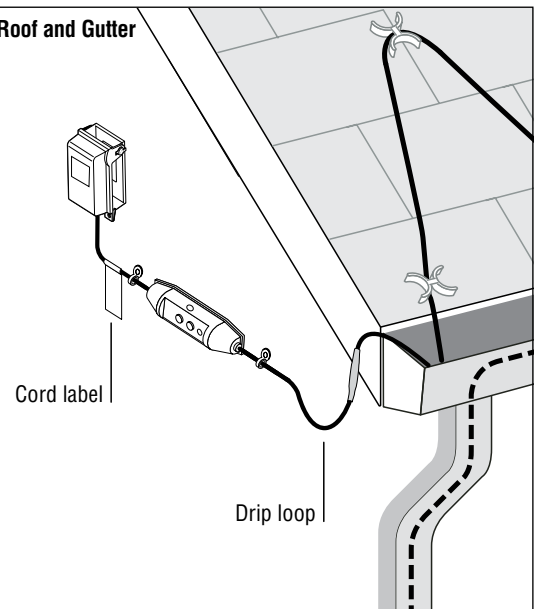

- Plug the heating cable into a 15-A, 120-Vac grounded outlet.
- Make sure that:
 - Cord label is readily visible.
 - Indicator light on the ground-fault equipment protection device is on.
 - Receptacle is properly weatherproofed (if outdoors).
 - Ground-fault equipment protection device and power connection splice will not be submerged.

Limited Warranty

During the time periods and subject to the conditions hereinafter set forth. Heat-Line will repair or replace to the original user any portion of your HTLN-GFC-KIT-120 product which proves defective in materials or workmanship of Heat-Line. Contact Heat-Line or your installer for warranty service.

At all times Heat-Line shall have and possess the sole right and option to determine whether to repair or replace defective equipment, parts or components. **Damage due to natural events or conditions beyond the control of Heat-Line are NOT COVERED BY THIS WARRANTY.**

STANDARD WARRANTY PERIOD: 2 years from date of purchase.

ACCESSORIES, COMPONENTS, ELECTRONICS: Not manufactured by Heat-Line, are warranted only to the extent of original manufacturer's warranty.

LABOUR, COSTS, ETC.: Heat-Line shall in **NO EVENT** be responsible or liable for the cost of field labour or other charges incurred by any customer in removing and/or reaffixing any Heat-Line product, part or component thereof.

THIS WARRANTY WILL NOT APPLY:

- (a) to defects or malfunctions resulting from failure to properly install, operate or maintain the unit in accordance with printed instructions provided,
- (b) to failures resulting from abuse, accident or negligence;
- (c) to normal maintenance services and
- (d) to parts not used in accordance with applicable local codes, ordinance and good trade practices;
- (e) if the unit is moved from its original installation location or
- (f) if the unit is used for purposes other than for what it was designed and manufactured,
- (g) to the integral ground fault device and related electronics.

PRODUCT IMPROVEMENTS: Heat-Line reserves the right to change or improve its products or any component thereof without being obligated to provide such a change or improvement for units sold and/or shipped prior to such change or improvement.

WARRANTY EXCLUSIONS: As to any Heat-Line product after the expiration of the time period of the warranty applicable thereto as set forth above. There will be no warranties including any implied warranties of merchantability or fitness for any particular purpose. No warranties or representations at any time made by any representative of Heat-Line, shall vary or expand the provisions hereof.

LIABILITY LIMITATION: In no event shall Heat-Line be liable or responsible for consequential, incidental or special damages resulting from or related in any manner to any Heat-Line product or parts thereof. In the absence of suitable proof of the purchase date, the effective date of this warranty will be based upon the date of manufacture plus 90 days.

Heat-Line Freeze Protection Systems

1095 Green Lake Road
Algonquin Highlands, ON Canada
KOM 1S0
Tel: 1-705-754-4545
1-800-584-4944
Fax: 1-705-754-4567
info@heatline.com
www.heatline.com

Heat-Line and EDGE-CUTTER are registered trademarks of Heat-Line Corporation.

Important: All information, including illustrations, is believed to be reliable. Users, however, should independently evaluate the suitability of each product for their particular application. Heat-Line a Division of Christopher MacLean Ltd. makes no warranties as to the accuracy or completeness of the information, and disclaims any liability regarding its use. Heat-Line's only obligations are those in the Heat-Line Standard Terms and Conditions of Sale for this product, and in no case will Heat-Line be liable for any incidental, indirect, or consequential damages arising from the sale, resale, use, or misuse of the product. Specifications are subject to change without notice. In addition, Heat-Line reserves the right to make changes—without notification to Buyer—to processing or materials that do not affect compliance with any applicable specification.