

Advanced Pipe and Roof Heating Cable Systems and Accessories



The Most Advanced Freeze Protection Systems in the World

Mission Statement:

The evenhanded operation of buying and selling is fundamental to the growth of all business. Over the years, companies have lost the sense for the importance of mutual respect between the people performing this exchange.

Truth, honesty and trust fuel our efforts toward our main objective to develop advanced and reliable freeze protection systems while offering extraordinary expertise and communications in this field.

It is of great importance to maintain ongoing research and development to create new products to enhance lifestyle in the most severe cold climates. With complete understanding of the products we sell, outstanding efforts in direct communications between all parties and our common desire to always achieve higher standards, we will never lose sight of our customer's needs.

Lorne R. Heise & Robin Heise,
Co-Founders of Heat-Line



Table of Contents

Heat-Line Distributor Sales Proposition.....	1	Kompensator [®]	43
Why Heat-Line?	2	Features/Specifications/Applications	44
Self-Regulating Technology.....	3	About Kompensator	45
Electrical Connection Options.....	5	Product Codes & Accessories	46
Heat-Line System Features & Benefits.....	6	Paladin [®] For Roof	47
Retro-Line [®]	7	Features/Specifications/Applications	48
Features/Specifications/Applications.....	8	About Paladin For Roof.....	49
About Retro-Line	9	Product Codes & Accessories	50
Product Codes & Accessories	10	EDGE-CUTTER [®]	51
Retro-Line [®] Mini	11	Features/Specifications/Applications	52
Features/Specifications/Applications.....	12	About EDGE-CUTTER	53
About Retro-Line Mini	13	Product Codes & Accessories	54
Product Codes & Accessories	14	ArcticVent [®]	55
Retro-DWS [®]	15	General Heater Specifications	56
Features/Specifications/Applications	16	About ArcticVent.....	57
About Retro-DWS.....	17	Ordering Chart & Product Codes	58
Product Codes & Accessories	18	ArcticVent [®] -HT	59
Retro-FM [®]	19	General Heater Specifications	60
Features/Specifications/Applications	20	About ArcticVent-HT.....	61
About Retro-FM.....	21	Ordering Chart & Product Codes	62
Product Codes & Accessories	22	Cut-To-Length Heating Cable	63
Rizer-Line	23	General Heater Specifications	64
Features/Specifications/Applications.....	24	About Cut-to-Length Heating Cable.....	65
About Rizer-Line	25	Ordering Chart & Product Codes	66
Product Codes & Accessories	26	Thermostats & Timers	67
CARAPACE [®]	27	Product Codes	68
Features/Specifications/Applications	28	Insulation	69
About CARAPACE.....	29	About Insulation/Product Codes/Accessories	70
Product Codes & Accessories	30	Philmac Fittings	71
Heat-Line [®]	31	About Philmac Fittings & Product Codes	72
Features/Specifications/Applications.....	32	Submersible Pump Stand and Wire	73
About Heat-Line	33	About/Product Codes/Accessories.....	74
Product Codes & Accessories	34	MilliAMP	75
Paladin/EXT [®]	35	About MilliAMP/Product Codes/Accessories.....	76
Features/Specifications/Applications.....	36	The Heat-Line Team	77
About Paladin/EXT	37	Notes	77
Product Codes & Accessories	38		
Tandem-Link	39		
Features/Specifications/Applications	40		
About Tandem-Link	41		
Product Codes & Accessories	42		

Intended use: This document is intended for recipient only as a shop copy. Commercial distribution not permitted. All information, including illustrations, is believed to be reliable. Users, however, should independently evaluate the suitability of each product for their particular application.

For conversions to metric system:

Meters	m	=	ft x 3.28
Watts/Meter	w/m	=	w/ft x 3.28
Degrees Celsius	°C	=	(°F - 32) x 0.55



In-Pipe Water Supply

Pg 7



In-Pipe Water Supply
Small-Diameter

Pg 11



In-Pipe Drain Waste Sewer

Pg 15



In-Pipe Force Main

Pg 19



Livestock Drinking Bowl
Heating Cable

Pg 23



Rural and Municipal
Water Supply Pipe

Pg 27



Rural Water Supply Pipe

Pg 31



On-Pipe and
In-Pipe Drains

Pg 35



On-Pipe Inter-Connecting

Pg 39



On-Pipe Low Voltage

Pg 43



Roof and Gutter
De-Icing Heating Cable

Pg 47



Advanced Roof Edge
De-Icing System

Pg 51



Freeze Protected
Plumbing Vent

Pg 55



Non-Electric Freeze
Protected Plumbing Vent

Pg 59



Cut-to-Length
Heating Cable

Pg 63



Thermostats and Timers

Pg 67



Pipe Insulation

Pg 69



Water Pipe
Compression Fittings

Pg 71



Submersible Pump Stand
and Wire

Pg 73



ELCI/GFC Protection

Pg 75



Heat-Line manufactures other innovative products including OEM products that are not mentioned in this catalogue.

Visit www.heatline.com for more information.

Heat-Line Distributor Sales Proposition

Contractors Face This Scenario Every Winter and Summer

With post-freeze repairs of existing water pipes after winter and new construction in summer, plumbing contractors are tasked to repair/replace fluid pipes and protect them from freezing. Over many years, various methods have been used. Some fail and some are successful, but never before have complete and proven systems been offered to the trades. Reliable systems that are designed and engineered to efficiently and safely resolve age-old freezing problems. Heat-Line invents, develops, manufactures and offers simple state-of-the-art systems that are a pleasure to install.

Traditional heating cable or hardware store heat tapes are the most common fix seen in the industry today. Often incorrectly installed and inexpensive to purchase, these systems can fail when traditional winters hit hard. For lack of a better way, these old systems are often found installed in situations and places far beyond their intended use, making safety an ongoing concern.

When a service call is required, each trade has its own specialty; plumbers are not electricians, and electricians are not plumbers. The result is expensive cross-trade service calls by the plumbing and electrical contractors. This always leads to heavy co-ordination expenses and costly delays.

In new construction projects, freeze protection is often specified in this manner, where the plumbing specification calls for the plumbing/mechanical contractor to buy the heating cable, and the electrical specification calls for electricians to design, install and connect the system. The plumbing/mechanical contractors must then return and insulate. Three installation processes for a single installation. This not only delays the installation but also introduces confusion regarding who is ultimately responsible for the installation and warranty.

Heat-Line systems remove the guess work and are engineered for the purpose of protecting pipes in the harshest environments. Heat-Line systems require no specialized terminations or testing. Every system is tagged, tested and factory certified to the high standards of North American regulatory agencies such as CSA and NSF.



Heat-Line Systems Provide a Value Advantage for Plumbing/Mechanical Contractors

Heat-Line freeze protection systems can be ordered ground fault protected, are designed to be installed by plumbing/mechanical contractors and meet requirements of CSA c-us for North America. The systems simply plug in. In addition, our internal pipe freeze protection systems are often installed in as little as 15 minutes. No electrical work is required, which allows plumbing/mechanical contractors to become a sole source solution for their customers.

Heat-Line systems are constructed with the highest quality self-regulating/conductive polymer, auto-therming heating cables and components. This allows contractors to safely insulate metallic or non-metallic (plastic) pipes. This ability to insulate greatly reduces energy costs compared with any other system on the market today.

IMPORTANT

Waterworks, mechanical and plumbing distributors can offer solutions to industry pipe freezing problems with Heat-Line Systems.

Why Heat-Line?

Innovation

Multiple patents for advanced freeze protection systems with a continuing effort to identify cold climate problems and resolve them with new industry-leading products, designed uniquely by tradespeople for installation by the trades.

Safety and Standards

Heat-Line is an industry leader in cutting-edge products that meet or exceed regulatory standards. Heat-Line products are certified by governing authorities such as CSA and NSF to meet rigid North American standards.

Research & Development

Heat-Line continually conducts new product development at their on-site Research and Development facility.

Heat-Line Designs and Tests in a Natural Laboratory

Corporate facilities are located in the harsh, cold and rocky environment of Haliburton, Ontario, Canada. Heat-Line's business operations are located on the Precambrian Shield where temperatures can reach -40°F and it is rare to excavate below the frost line.

Real World Installation

Heat-Line was founded by a licensed, practicing electrician in 1988. All products are built from the tradesperson's point of view, and meticulous consideration is given to the installation requirements of every product design. Quality of materials are paramount and only the finest are used. Heat-Line products can be found protecting pipes as far north as Eureka in Nunavut, Canada, and as far south as Antarctica.

Industry-Leading Knowledge

Since 1988, Heat-Line has maintained successful continuous operation and company growth. Company staff have expanded to include tradespeople, scientists, engineers, sales technicians, support staff and administration personnel. Heat-Line is an award winning company that constantly stays in touch with cold climate needs by always developing new products.

Manufacturing

All systems are manufactured and assembled in North America (Canada and the United States) using North American made raw materials.



Heat-Line Self-Regulating Heating Cables

All Heat-Line products are self-regulating. The benefit of self-regulating is that unlike constant wattage heaters, there is no concern about underheating or overheating, even when insulated.

Heat-Line products offer cost-effective operation and maintenance reliability. The unique, self-regulating technology enables each Heat-Line product to vary its power output in response to temperature at every point along its length. As the temperature increases, Heat-Line products automatically decrease their heat output, and vice versa. The result is energy savings; the heating cable decreases heat when not required and rapidly increases heat when and where necessary. Heat-Line systems continually compensate for temperature fluctuations.



How Self-Regulating Technology Works

All Heat-Line heating cables are specially blended combinations of polymer and conductive carbon that create electrical paths between parallel buss wires at every point along their circuit. As the surrounding ambient temperature (water or air) cools, the heater core contracts microscopically. This contraction decreases resistance and increases power output. The resulting increase in power output – and thus heat – compensates for installation variables.

As the heating cables warm, the cores expand microscopically, resulting in reduced power output. The reduced power output minimizes operating energy costs and eliminates maintenance costs due to hot spots or burnout's. Heat is applied safely and efficiently when and where needed.

Heating Cable Construction And Operation

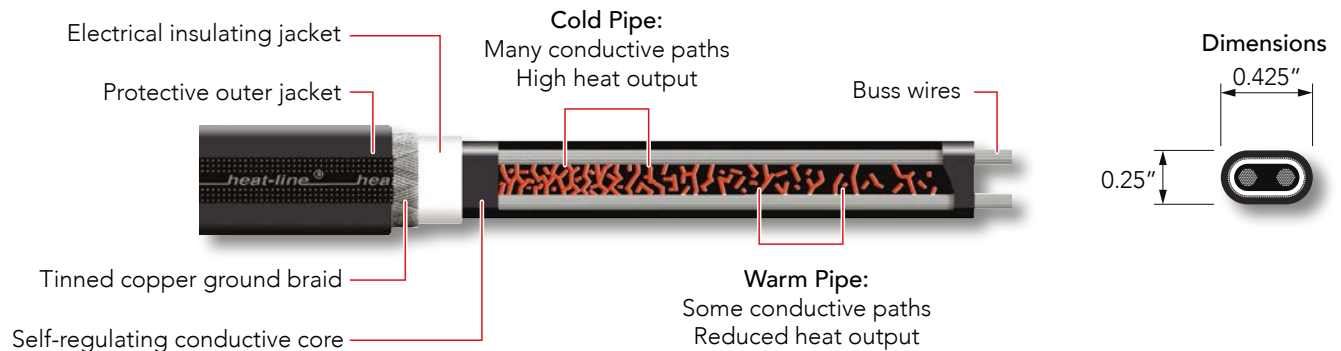

Energy Consumption Case Study

A question commonly asked is 'what will it cost to operate my Heat-Line system?' There is no exact answer as the self-regulating heating cable technology allows the heat (watt) output to adjust microscopically along the heating cable length depending on surrounding temperatures. See the Heat-Line Self-Regulating Heating Cables section (P. 3) for more about Heat-Line's technology. Every application is different and is exposed to different temperatures. What we do know is how efficient your system operates depends a lot on the installation. Use pipe insulation wherever possible and use a control device such as a thermostat and/or timer.

Below is a case study of a real life application provided to help you understand the energy efficiency of Heat-Line systems. This study was completed with a CARAPACE system which employs similar technology to any Heat-Line heating cable system.



LOCATION

- Carnarvon, ON, CANADA
- 45°02'43"N | 78°41'53"W
- 1,090 ft elevation above sea level



PRODUCT

- CARAPACE, 1 in Rural (ID controlled), 240 volt, 5w/ft @ 50°F
- System length; 270 ft, 90 ft on land, 180 ft in the lake
- 90 ft of pipe insulation on land, no pipe insulation in the lake
- Thermostat installed with a set point of 50°F (10°C)
- Sensor location 45 ft from the building, located on the pipe under insulation



PROPERTY

- Building located 90 ft from water's edge at an elevation of 30 - 40 ft above lake level
- Rock terrain, rock shoreline



LAKE

- Sand lake bed, no obstructions
- 4 ft water depth at 110 ft from shoreline
- 10 ft water depth at 150 ft from shoreline
- 20 ft water depth at 170 - 180 ft from shoreline



DURATION

- Powered on November 10, 2007
- Powered off April 25, 2008
- 70 days recorded temperatures

TEST RESULTS

167 Days of Total Operation

TOTAL COST \$91.05

Coldest recorded temp.	-27.4°F (-33°C)
Warmest recorded temp.	48.2°F (9°C)
Average temp.	17.7°F (-8°C)
Kilowatt usage	1,821 kW/h
Price per kw/h (April 2008)	\$0.05
Total Cost	\$91.05

*Disclaimer: Energy consumption will change depending on product selection, application, location and climate. This case study should be used as an example only, but exemplifies the high performance capability of the product.

Electrical Connection Options GFC vs CS

All Heat-Line brand heating cable systems are available in 120 or 240 volts and have the option to have either a GFC (ground fault protected, plug-in) or CS (cord set, hard wire). The only exception is Kompensator which is low voltage, 12 or 24 volts and available in CS only. When no electrical connection option is stated on an order GFC is always the default unless accessories are also ordered requiring the CS option for proper connection.

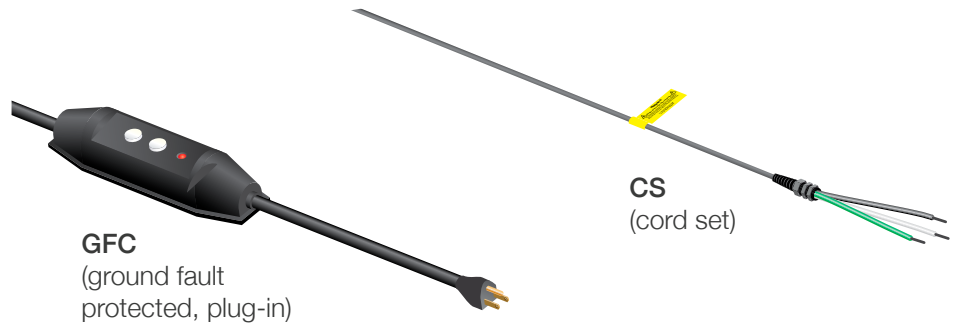

Note: (GFC may not always be supplied as shown)

GFC

Ground fault protected with an integral 27/30 milliamp ELCI which plug into a standard 120 volt or 240 volt receptacle. We recommend the use of specification grade receptacles (CSA 5-15R for 120 volt) and (CSA 6-15R for 240 volt). Cording is #14 or #12 SJEOOW depending on system length.

Ground fault protected systems are ordered with a suffix – “GFC” after the product number.

CS

Cord-Set only, the product is supplied with a 6 foot long #14 or #12 SJEOOW cord depending on system length, with a 6 inch knock-out strain relief fitting. Ground fault circuit protection must be field installed with these systems. These systems are also used when the systems are installed with our GFA-STAT which is a Nema 4X thermostat with integral 30 milliamp GFEP or other accessories requiring a hard wire connection.

Cord-Set systems are ordered with a suffix – “CS” after the product number.

Note: The CEC (Canadian Electrical Code) and the NEC (National Electrical Code – USA) require ground fault equipment protection on all heating cable systems.

Heat-Line System Features & Benefits

All Heat-Line heating cable products are self-regulating, offering cost-effective operation and maintenance reliability. Specially blended combinations of polymer and conductive carbon create a unique heating cable product advantage that no traditional heat tape can equal. There is no concern of under and or overheating. Whether for the rural home and cottage, industrial and commercial facilities, transportation industry, farms and agriculture and or temporary mines and discovery camps; Heat-Line pipe products provide reliable protection where freezing temperatures can cause serious damage to expensive and necessary equipment. Customers rely on Heat-Line's exceptional freeze protection systems and heating cable to keep water and other liquids flowing in extreme climates and circumstances. As you review the Heat-Line product group, you will see the unique style and engineering that is employed in every design.

Features and Benefits in every Heat-Line system

- cCSAus approved (Canada and USA) LR85446
- Self-regulating/conductive polymer heating cable
- Standard wattages 3, 5, 8 watts/foot at 50°F
- Systems available in 120V and 240V, 12V and 24V
- Custom lengths available
- Available with either GFCI plug or CS hard wire connection (120V and 240V)
- Engineered proprietary end seal technology
- Standard warranty of 5 yrs with optional 10 yrs (most 120V and 240V systems)
- Factory finished, job-ready – no liability for connections
- Each finished system is tested prior to shipment
- Single trade installation where a receptacle is within reach
- Manufactured to finished lengths for individual service requirements
- Suitable for installation with plastic or metal pipes
- Can be fully insulated to maximize energy efficiency
- Unlimited optional control devices such as thermostats and timers
- Thermostats not required for applications where they are not beneficial
- Will never melt or overheat, even if pipe is dry
- Extremely energy efficient
- Proven, reliable installations successful over 30 years
- Manufactured in North America
- Clear, concise installation and support documentation
- Quick turnaround time
- Best warranty in the business
- Extremely high quality, consistent product, top quality control procedures
- Fully backed and supported; Heat-Line offers technical advice and assistance



Retro-Line®

Leading Advanced Internal Water Supply Pipe Freeze Protection Systems.

Retro-Line is a job-ready freeze protection kit designed to be installed in minutes inside existing water supply pipes from 3/4" to 2" of many piping materials.



See more product information, videos, photos, technical documents, and more



Patents USA and Canada

NSF/ANSI 61

Retro-Line

Features & Benefits

- The only manufactured, self-regulating heating cable for in-pipe applications
- Multiple plumbing fittings available – Tees in ID-IPS, CTS and OD-IPS sizes, MIPT threads in 1 inch to 2 inch sizes
- Available in a plug-in GFCI model or hard wire cord-set model depending on application
- Completely customizable for various application requirements
- Length can be adjusted (shortened) on the job-site by means of extracting the heating cable through plumbing fitting (contact Heat-Line for guidance)
- Available in common lengths and long lengths
- Suitable for pipe diameters ¾ inch to 2 inch, for larger pipe diameters see Retro-FM
- Withstands water pressure up to 230 PSI
- Suitable for installation in plastic or metal pipes
- Can be installed into existing pipes without excavation
- Can be pushed in most pipes up to 150 feet
- Long systems can be drawn in with fish tape or twine
- Lengths 40 feet and greater are supplied on a dispensing reel for ease of installation
- Heating cable is rigid enough to stay in place within the entire length of pipe, no downward fastening device
- Fully serviceable, can easily be removed if necessary
- Suitable for above ground applications with insulation
- Suitable for sump pump lines
- Will never melt or overheat, even if pipe is dry
- Proven in -40°F weather above ground with ¾ inch polyethylene insulation



Specifications

- cCSAus approved (Canada and USA) LR85446
- NSF/ANSI 61 Drinking Water Safe
- Approved for potable drinking water
- Certified Usage Type P and X Canada
- Installation Type D USA
- Self-regulating/conductive polymer heating cable
- Fluoropolymer outer jacket
- Standard wattage 3 W/ft @ 50°F (10 W/m @ 10°C), special wattage available
- Available in 120V and 240V
- Max lengths 120V - 230 ft, 240V - 550 ft
- Available with either GFCI plug or CS hard wire connection
- Proprietary end seal technology engineered for applications up to 230 PSI
- Standard warranty of 5 yrs with optional 10 yrs

Applications

- Existing water supply lines subject to freezing
- Rural home and business water supply systems
- Sump pump lines
- Lake homes and cottages/cabins
- Wells
- Farms, agriculture/commercial, industrial/construction sites
- Camps/mining
- Lake/river source waterline
- Certain municipal water supplies

For more Features and Benefits common to all Heat-Line systems, refer to page 6.



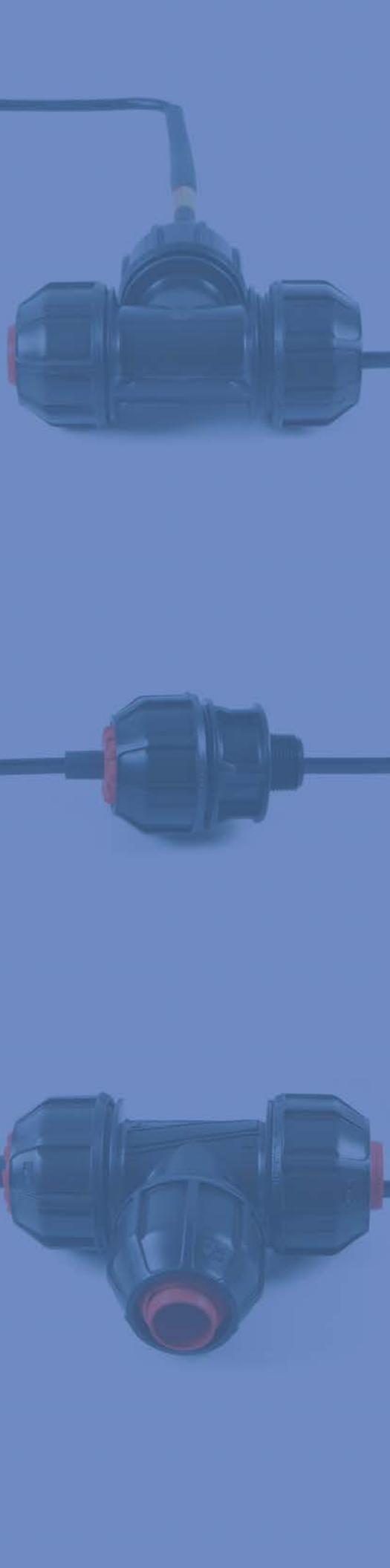

Internal Water Supply Freeze Protection

Retro-Line is an internal self-regulating heat tracing system designed to provide freeze protection of existing water supply and fluid pipes without their removal. Insulation and an optional thermostat can be used to optimize energy efficiency.

CSA/NSF Approved

Retro-Line is the only cCSAus NSF/ANSI 61 Drinking Water approved, internal self-regulating P and X factory finished freeze protection system available on the market.

Complete System

The Retro-Line system is supplied in a predetermined length with all necessary components for a complete system. For polyethylene pipe applications Retro-Line is supplied with a compression fitting for connection to the pipe.

Multiple Interfacing

An ID controlled tee fitting for polyethylene pipe is supplied standard with the Retro-Line system. Retro-Line can also be ordered with a CTS controlled tee or a threaded male adapter for easy interfacing to pipe such as ABS, PVC, PEX, copper, galvanized and steel.

Requirements

Retro-Line orders require the length of heating cable and pipe size for polyethylene installations or male adapter thread size for other pipe installations. System lengths are 120 volt up to 230 feet and 240 volt up to 550 feet. Minimum pipe size required is 3/4 inch ID.

Fully Serviceable

Short Retro-Lines can simply be pushed into the pipe while longer systems may be pulled in using a fish tape. The downward end of the cable does not need to be internally fastened, as it will not re-coil, which is extremely important as it renders the system fully serviceable. The system can be removed and replaced should it become necessary.

Easy Installation

Heat-Line developed a unique, patented dispensing system called "Retro-Reel" to protect the heating cable and fittings from mechanical injury while the product is deployed into the pipe with absolute ease. It is not unusual to push systems in up to 250 feet and sometimes more.

Versatile Application

Retro-Line can be used in a variety of applications, including metal and plastic water supply, sump pump lines and pressurized or high volume drain pipes.

Retro-Line | Product Code Guide

Example: **RL - 125 - 100 - CTS - GFC**

Product	RL 120 V Retro-Line RL2 240 V Retro-Line	Cord-Set Type	GFC Ground fault protected 5-15 P 120 V / 6-15 P 240 V CS Cord connected (no GFCI)
Fitting/Pipe Size	075 Fitting/pipe size 3/4" * 100 Fitting/pipe size 1" 125 Fitting/pipe size 1 1/4" ** 150 Fitting/pipe size 1 1/2" 200 Fitting/pipe size 2"***	Fitting Type	ID Internal pipe diameter ID-IPS tee fitting CTS Copper tubing size CTS tee fitting OD Outside pipe diameter OD-IPS tee fitting IP Male adapter (thread size) MIPT fitting NI 1" and 1 1/4" kit internal pipe diameter ID tee
	* Not available in IP ** NI fitting type must chose 125 *** Not available in CTS	Length of System	120 V max length 230 ft 240 V max length 550 ft

NOTE: The heating cable is measured and cut to the length of system ordered. Some of this length will remain within the interface fitting. Nominal power output of Retro-Line system is 3 W/ft @ 50°F (10 W/m @ 10°C). Only available in Drinking Water Safe Fluoropolymer outer heating cable jacket.

Retro-Line | Accessories

HLJ-STAT	120V plug-in thermostat (GFC)	INSUL-1.00	Insulation sleeve for 1 inch ID pipe (1 5/8 inch ID, 6 ft long)
HLA-120	120V plug-in thermostat (GFC)	INSUL-1.25	Insulation sleeve for 1 1/4 inch ID pipe (1 7/8 inch ID, 6 ft long)
GFA-STAT	120/240V hard wire thermostat GFEP (CS)	INSUL-2.00	Insulation sleeve for 2 inch ID pipe (2 5/8 inch ID, 6 ft long)
TIMER-120P	120V plug-in timer (GFC)	HLP-TAPE	Tape for insulation sleeve butt joints (100 ft)
TIMER-240P	240V plug-in timer (GFC)	WARRANTY	Extended 10 year limited warranty
TIMER-CS	120/240V hard wire timer (CS)		
MA-10	120/240V GFCI/ELCI (CS)		

Retro-Line | Sample Installation

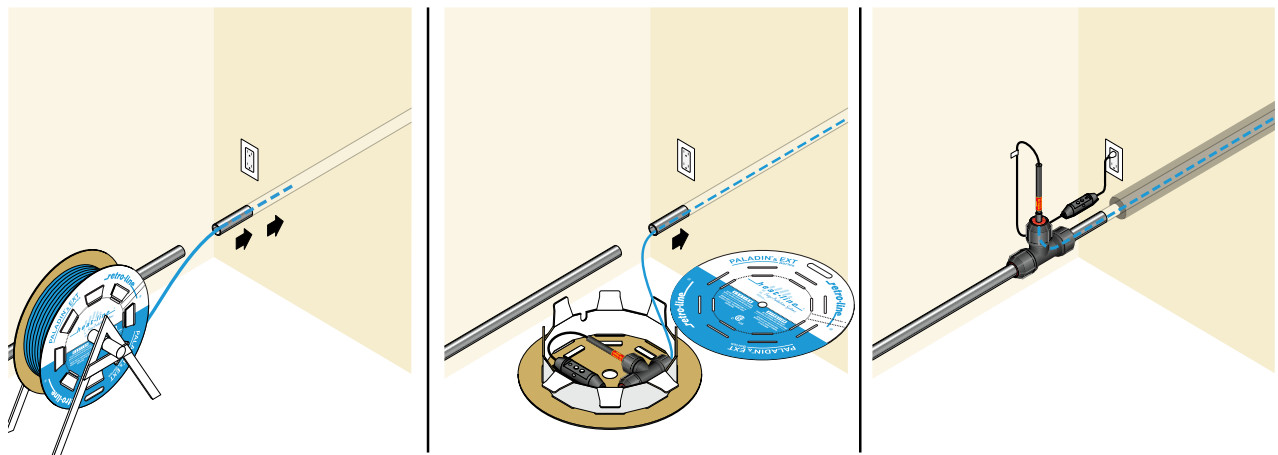

Retro-Line[®] Mini

Leading Advanced Internal Water Supply Pipe Freeze Protection Systems.

Retro-Line Mini is a job-ready freeze protection kit designed to be installed in minutes inside existing small diameter water supply pipes and drains from ½" to 1" of many piping materials.



See more product information, videos, photos, technical documents, and more



Patents USA and Canada NSF/ANSI 61

Retro-Line Mini

Features & Benefits

- The only manufactured, self-regulating heating cable for in-pipe applications
- Multiple plumbing fittings available – Tees in ID-IPS, CTS and OD-IPS sizes, MIPT threads in ½ inch, ¾ inch and 1 inch sizes
- Available in a plug-in GFCI model or hard wire cord-set model depending on application
- Completely customizable for various application requirements
- Length can be adjusted (shortened) on the job-site by means of extracting the cable through plumbing fitting (contact Heat-Line for guidance)
- Available in common lengths
- Suitable for pipe diameters ½ inch to 1 inch, for larger pipe diameters see Retro-Line
- Withstands water pressure up to 230 PSI
- Suitable for installation in plastic or metal pipes
- Can be installed into existing pipes without excavation
- Can be pushed in most pipes up to 100 feet
- Long systems can be drawn in with fish tape or twine
- Lengths 40 feet and greater are supplied on a dispensing reel for ease of installation
- Heating cable is rigid enough to stay in place within the entire length of pipe, no downward fastening device
- Fully serviceable, can easily be removed if necessary
- Suitable for above ground applications with insulation
- Suitable for sump pump lines
- Will never melt or overheat, even if pipe is dry
- Proven in -40°F weather above ground with ¾ inch polyethylene insulation



Specifications

- cCSAus approved (Canada and USA) LR85446
- NSF/ANSI 61 Drinking Water Safe
- Approved for potable drinking water
- Certified Usage Type P and X Canada
- Installation Type D USA
- Self-regulating/conductive polymer heating cable
- Fluoropolymer outer jacket
- Standard wattage 3 W/ft @ 50°F (10 W/m @ 10°C), special wattage available
- Max length 130 ft
- Available with either GFCI plug or CS hard wire connection
- Proprietary end seal technology engineered for applications up to 230 PSI
- Standard warranty of 5 yrs with optional 10 yrs

Applications

- Small diameter – problematic municipal service tubes
- Small diameter sump pump discharge pipes
- Well water supply lines, including dug, drilled and artesian wells
- Building to building water supply
- Commercial/ Industrial Facilities
- Suitable for jet pump and submersible pump applications

For more Features and Benefits common to all Heat-Line systems, refer to page 6.





Internal Water Supply Freeze Protection

Retro-Line Mini is an internal self-regulating heat tracing system designed to provide freeze protection of existing small diameter water supply and fluid pipes without their removal. Insulation and an optional thermostat can be used to optimize energy efficiency.

CSA/NSF Approved

Retro-Line Mini is the only cCSAus NSF/ANSI 61 Drinking Water approved, internal self-regulating P and X factory finished freeze protection system for small diameter pipes available on the market.

Complete System

The Retro-Line Mini system is supplied in a predetermined length with all necessary components for a complete system. For polyethylene pipe applications Retro-Line Mini is supplied with a compression fitting for connection to the pipe.

Multiple Interfacing

An ID controlled tee fitting for polyethylene pipe is supplied standard with the Retro-Line Mini system. Retro-Line Mini can also be ordered with a CTS controlled tee or a threaded male adapter for easy interfacing to pipe such as ABS, PVC, PEX, copper, galvanized and steel.

Requirements

Retro-Line Mini orders require the length of heating cable and pipe size for polyethylene installations or male adapter thread size for other pipe installations. System lengths are 3 W/ft 120 V up to 130 feet and 5 W/ft 120 V up to 100 feet . Minimum pipe size required is ½ inch ID.

Fully Serviceable

Short Retro-Line Minis can simply be pushed into the pipe while longer systems may be pulled in using a fish tape. The downward end of the cable does not need to be internally fastened, as it will not re-coil, which is extremely important as it renders the system fully serviceable. The system can be removed and replaced should it become necessary.

Easy Installation

Heat-Line developed a unique, patented dispensing system called “Retro-Reel” to protect the heating cable and fittings from mechanical injury while the product is deployed into the pipe with absolute ease. It is not unusual to push systems in up to 100 feet.

Versatile Application

Retro-Line Mini can be used in a variety of applications, including small diameter metal and plastic water supply, sump pump lines and pressurized or high volume drain pipes.

Retro-Line Mini | Product Code Guide

Example: **RLM - 3 - 050 - 130 - ID - CS**

Product

RLM 120 V Retro-Line Mini

Nominal Power Output

3 3 W/ft @ 50°F (10 W/m @ 10°C)
5 5 W/ft @ 50°F (16 W/m @ 10°C)

Fitting/Pipe Size

050 Fitting/pipe size ½" *
075 Fitting/pipe size ¾"
100 Fitting/pipe size 1" **

* Not available in CTS or OD Tee sizes

** Not available in ID, OD or IP fitting sizes

Cord-Set Type

GFC Ground fault protected
5-15 P 120 V
CS Cord connected (no GFCI)

Fitting Type

ID Internal pipe diameter ID-IPS tee fitting
CTS Copper tubing size CTS tee fitting
OD Outside pipe diameter OD-IPS tee fitting
IP Male adapter (thread size) MIPT fitting

Length of System

3 W/ft 120 V max length 130 ft
5 W/ft 120 V max length 100 ft

NOTE: The heating cable is measured and cut to the length of system ordered. Some of this length will remain within the interface fitting. Only available in Drinking Water Safe Fluoropolymer outer heating cable jacket. Minimum pipe inside diameter must be 0.485" or greater. Cold water use only.

Retro-Line Mini | Accessories

HLJ-STAT 120V plug-in thermostat (GFC)
HLA-120 120V plug-in thermostat (GFC)
TIMER-120P 120V plug-in timer (GFC)
TIMER-CS 120/240V hard wire timer (CS)
MA-10 120/240V GFCI/ELCI (CS)

INSUL-1.00 Insulation sleeve for 1 inch ID pipe (1 5/8 inch ID, 6 ft long)
HLP-TAPE Tape for insulation sleeve butt joints (100 ft)
WARRANTY Extended 10 year limited warranty

Retro-Line Mini | Sample Installation

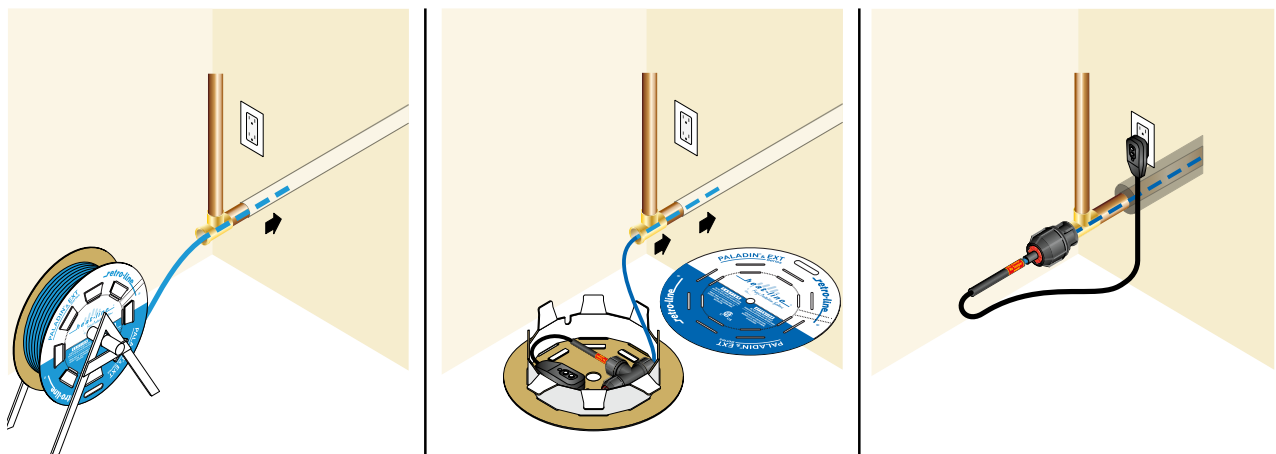

Retro-DWS®

Internal Tubular Freeze Protection System for Non-Pressurized Drain, Waste and Sewer Pipe Applications.

Retro-DWS (Drain Waste Sewer) supplied job-ready to internally heat trace common 4 inch septic and sewage pipe applications with an optional 3 inch adaptor kit available as an add on. The product can be easily adapted to a variety of drainage pipes and fit larger sized septic, storm drain and sewage pipes by using readily available components.



See more product information, videos, photos, technical documents, and more

Patents USA and Canada



Retro-DWS

Features & Benefits

- The only in-pipe system designed specifically for grey and black water applications
- Factory finished, job-ready – no liability for installer
- Each finished system is tested prior to shipment
- Single trade installation where a receptacle is within reach
- Manufactured to finished lengths for individual service requirements
- Plumbing fittings supplied to adapt to 4 inch ABS clean-out (3 inch kit optional add on)
- Available in a plug-in GFCI model or hard wire cord-set model depending on application
- Completely customizable for various application requirements
- Length can be adjusted (shortened) on the job-site by means of extracting the cable through plumbing fitting
- Available in common lengths and long lengths
- Suitable for pipe diameters 3 inch and larger
- Suitable for non-pressurized pipe, for pressurized systems see Retro-FM
- Suitable for installation in plastic or metal pipes
- Can be installed into existing pipes without excavation
- Can be pushed in most pipe up to 150 feet
- Long systems can be drawn in with fish tape or twine
- Fully serviceable, can be removed if necessary
- Suitable for above ground applications with insulation
- Will never melt or overheat, even if pipe is dry
- Heating cable is protected within ½ inch HDPE pipe

Specifications

- cCSAus approved (Canada and USA) LR85446
- Certified Usage Type W Canada
- Installation Type D USA
- Internal waste (grey and black) water certified
- Self-regulating/conductive polymer heating cable
- Tubular Heater (heating cable installed inside HDPE polyethylene)
- Standard wattage 5 W/ft @ 50°F (16 W/m @ 10°C), special wattage available
- Available in 120V and 240V
- Max lengths 120V - 230 ft, 240V - 540 ft
- Available with either GFCI plug or CS hard wire connection
- Standard warranty of 5 yrs with optional 10 yrs

Applications

- Existing fresh water drains, storm drains and sewer subject to freezing
- Rural homes, cottages, farms
- Commercial, industrial, municipal
- Storm drains under parking lots
- Storm sewers, sewers, culverts
- Camps, mining
- Wherever blasting would be required to reach frost line

For more Features and Benefits common to all Heat-Line systems, refer to page 6.





Internal Tubular Freeze Protection

Retro-DWS is an internal tubular heating cable system designed to provide freeze protection for existing problematic drains, sewers and culverts without the need to excavate. Insulation and thermostatic control can be added to optimize energy efficiency as required.

Complete System

The Retro-DWS is constructed with Heat-Line certified, self-regulating heating cable factory installed inside a ½ inch HDPE tube with a factory applied fusion end-seal. The system is manufactured to a predetermined length and is supplied complete with all necessary plumbing components. The components supplied interface with 4 inch ABS pipes using an existing or installed clean-out, Tee or Wye as an access point. A 3 inch adaptor kit is available as an optional add on and if required, the Retro-DWS can be easily adapted to fit larger pipe diameters by using readily available, industry standard components.

Interface Versatility

The versatile interface process of the Retro-DWS makes the system suitable for installation in pipe diameters from 3 inches to greater than 8 inches. In larger pipe applications, Retro-DWS is designed to provide a melt-water path, thus allowing continuous flow through the entire channel. This allows the fluids to carve their way through large diameter culverts or drains without having to install energy-expensive high watt density heat cables.

Will Not Overheat

The self-regulating heating cable technology renders the system safe to use in all metal and non-metal pipes. Even if the pipe is dry, the self-regulating heating cable presents no danger of overheating, making it suitable for drain lines that do not always contain liquids.

Retro-DWS is the only heating cable system designed to protect drain, storm drain, culvert, waste and sewer systems. These include but are not limited to septic tanks, holding tanks and other similar applications. Retro-DWS can be used as a system to prevent freezing or as a precautionary system to use only if a freeze-up occurs.

Fully Serviceable

The Retro-DWS is a fully serviceable product. If a blockage occurs, the entire heat system can be removed and re-installed.

Requirements

When ordering Retro-DWS you will need to know the length of heating cable that is required. System lengths are 120 volt up to 230 feet and 240 volt up to 540 feet. Longer systems are available by special order. Minimum pipe size required is 3 inch ID.

Important Considerations

Retro-DWS defends against many various and difficult freezing processes and conditions. The use of his product and its compatibility with a particular application is at the complete discretion of the user. The possibility exist that this product may cause an obstruction, especially where foreign objects or solids may flow in direct contact with it. A service schedule is recommended.

Retro-DWS | Product Code Guide

Example: **DWS - 5 - 100 - GFC**

Product		Cord-Set Type
DWS	120 V Retro-DWS	GFC Ground fault protected
DWS2	240 V Retro-DWS	5-15 P 120 V / 6-15 P 240 V
Nominal Power Output		CS Cord connected (no GFCI)
5	5 W/ft @ 50°F (16 W/m @ 10°C)	Length of System
8	8 W/ft @ 50°F (26 W/m @ 10°C)	GFC Ground Fault Protected
		CS Cord Connected (no GFCI)
		<i>Max length</i>
		5 W/ft 120 V 230 ft
		8 W/ft 120 V 150 ft
		5 W/ft 240 V 460 ft
		8 W/ft 240 V 300 ft

NOTE: Installers must provide 20 Amp circuits for CS circuit lengths greater than 460 ft for 5 W/ft and 300 ft for 8 W/ft systems.

Retro-DWS | Accessories

DWS-3.00-KIT	3 inch pipe adaptor kit, includes coupler and threaded male adapter	INSUL-3.00	Insulation sleeve for 3 inch ID pipe (3 ½ inch ID, 6 ft long)
HLJ-STAT	120V plug-in thermostat (GFC)	INSUL-4.00	Insulation sleeve for 4 inch ID pipe (4 ½ inch ID, 6 ft long)
HLA-120	120V plug-in thermostat (GFC)	HLP-TAPE	Tape for insulation sleeve butt joints (100 ft)
GFA-STAT	120/240V hard wire thermostat GFEP (CS)	INSUL-FOIL	Aluminum bubble foil insulation (16 in wide, sold by the foot)
TIMER-120P	120V plug-in timer (GFC)	INSUL-TAPE	All weather aluminum foil tape (150 ft)
TIMER-240P	240V plug-in timer (GFC)	TORQ-60	No hub torque wrench automatic release at 60 IN. LB.
TIMER-CS	120/240V hard wire timer (CS)	WARRANTY	Extended 10 year limited warranty
MA-10	120/240V GFCI/ELCI (CS)		

Retro-DWS | Sample Application

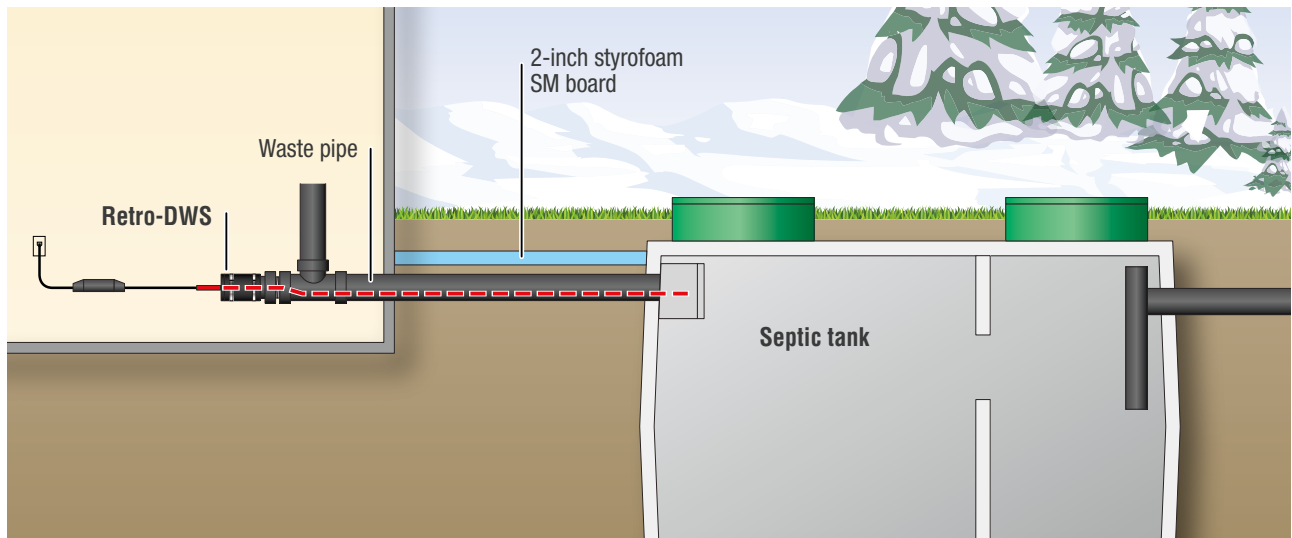

Retro-FM[®]

Internal Tubular Freeze Protection System for Pressurized Sewage, Force Main and Large Diameter Potable Pipe Applications.

Retro-FM (Force Main) self-regulating heating cable systems are supplied job-ready to internally heat trace pressurized sewage force main applications. Retro-FM can be easily adapted to a variety of pipes and can also be interfaced to larger diameter potable pipes by using readily available bushings and fittings.



See more product information, videos, photos, technical documents, and more



Patents USA and Canada NSF/ANSI 61

Retro-FM

Features & Benefits

- The only in-pipe system designed for grey/black water and potable water applications
- Multiple fittings supplied – 1 inch non-metallic MIP staged fitting for connection and 1 inch FIP X 2 inch MIP PVC reducing bushing
- Available in a plug-in GFCI model or hard wire cord-set model depending on application
- Completely customizable for various application requirements
- Available in common lengths and long lengths
- Suitable for pipe diameters 2 inch and larger
- Withstands water pressure up to 230 PSI
- Suitable for installation in plastic or metal pipes
- Can be installed into existing pipes without excavation
- Can be pushed in pipe up to 150 feet
- Long systems can be drawn in with fish tape or twine
- Fully serviceable, can be removed if necessary
- Can be fully insulated to maximize energy efficiency
- Suitable for above ground applications with insulation
- Will never melt or overheat, even if pipe is dry

For more Features and Benefits common to all Heat-Line systems, refer to page 6.



Specifications

- cCSAus approved (Canada and USA) LR85446
- NSF/ANSI 61 Drinking Water Safe
- Approved for potable drinking water
- Certified Usage Type P and X Canada
- Installation Type A USA
- Self-regulating/conductive polymer heating cable
- Tubular Heater (heating cable installed inside HDPE polyethylene)
- Standard wattage 5 W/ft @ 50°F (16 W/m @ 10°C), special wattage available
- Available in 120V and 240V
- Max lengths 120V - 230 ft, 240V - 540 ft
- Available with either GFCI plug or CS hard wire connection
- 20 foot power supply lead
- End seal termination certified to pressures up to 230 PSI
- Standard warranty of 5 yrs with optional 10 yrs

Applications

- Rural homes, cottages, farms, commercial, industrial, municipal
- Storm drains under parking lots
- Storm sewers
- Sewers, sewage force mains
- Camps, mining
- Wherever blasting would be required to reach frost line





Internal Tubular Freeze Protection

Retro-FM is a tubular self-regulating heating system designed for use in pressurized sewage and greywater force mains and large diameter pressurized potable water pipes.

CSA/NSF Approved

Retro-FM is cCSAus NSF/ANSI 61 Drinking Water approved, usage P and X. The core tube is constructed of HDPE (high density polyethylene) and will push inside most pipes for long distances. It can also be drawn in with a fish tape or rope. Retro-FM utilizes a conductive polymer tubular heater technology, which provides a barrier from fluids while providing extremely efficient freeze protection.

Protects Potable Water Pipes

Retro-FM is designed to protect many large pressurized pipe systems that contain fluids that are compatible to be in contact with polyethylene, including potable water pipes. Retro-FM (Force Main) self-regulating heating cable systems are supplied job-ready to internally heat trace pressurized sewage force main applications. Retro-FM can be easily adapted to a variety of pipes and can also be interfaced to larger diameter potable pipes by using readily available bushings and fittings.

Compatible for All Pipes

The system is compatible for use with all pipe types, including metal and non-metal. Even if the pipe is dry, the tubular heater presents no danger of overheating even when thermally insulated. This is very important for use in pipes that drain back or are periodically dry.

Customization

Retro-FM employs Heat-Line's self-regulating technology applied within a factory assembled, fusion sealed HDPE tube. The systems are custom manufactured to specified lengths and come with a 20 foot SJEOOW hard usage cord-set, with or without integral ground fault circuit protection.

Job Ready to Quickly Interface Fittings

Retro-FM is supplied job-ready with a 1 inch non-metallic MIP staged fitting to quickly interface into force main tee or wye fittings. The product can be used in a variety of applications.

Prevention or Precaution

Retro-FM can be used as a system to prevent freezing or as a precautionary system. If the system freezes, Retro-FM can be energized to begin the thawing process.

No Need to Excavate

Retro-FM provides freeze protection for existing problematic pipes without the need to excavate. Insulation and thermostatic controls can be added to optimize energy efficiency as required.

Retro-FM | Product Code Guide

Example: **FM - 5 - 100 - GFC**

Product		Cord-Set Type	
FM	120 V Retro-FM	GFC	Ground fault protected
FM2	240 V Retro-FM		5-15 P 120 V / 6-15 P 240 V
		CS	Cord connected (no GFCI)
Nominal Power Output		Length of System	
5	5 W/ft @ 50°F (16 W/m @ 10°C)	GFC Ground Fault Protected	CS Cord Connected (no GFCI)
8	8 W/ft @ 50°F (26 W/m @ 10°C)	<i>Max length</i>	<i>Max length</i>
		5 W/ft 120 V	230 ft
		8 W/ft 120 V	150 ft
		5 W/ft 240 V	460 ft
		8 W/ft 240 V	300 ft

NOTE: Installers must provide 20 Amp circuits for CS circuit lengths greater than 460 ft for 5 W/ft and 300 ft for 8 W/ft systems.

Retro-FM | Accessories

HLJ-STAT	120V plug-in thermostat (GFC)	INSUL-3.00	Insulation sleeve for 3 inch ID pipe (3 ½ inch ID, 6 ft long)
HLA-120	120V plug-in thermostat (GFC)	INSUL-4.00	Insulation sleeve for 4 inch ID pipe (4 ½ inch ID, 6 ft long)
GFA-STAT	120/240V hard wire thermostat GFEP (CS)	HLP-TAPE	Tape for insulation sleeve butt joints (100 ft)
TIMER-120P	120V plug-in timer (GFC)	INSUL-FOIL	Aluminum bubble foil insulation (16 in wide, sold by the foot)
TIMER-240P	240V plug-in timer (GFC)	INSUL-TAPE	All weather aluminum foil tape (150 ft)
TIMER-CS	120/240V hard wire timer (CS)	WARRANTY	Extended 10 year limited warranty
MA-10	120/240V GFCI/ELCI (CS)		
INSUL-2.00	Insulation sleeve for 2 inch ID pipe (2 5/8 inch ID, 6 ft long)		

Retro-FM | Sample Rural Septic Application

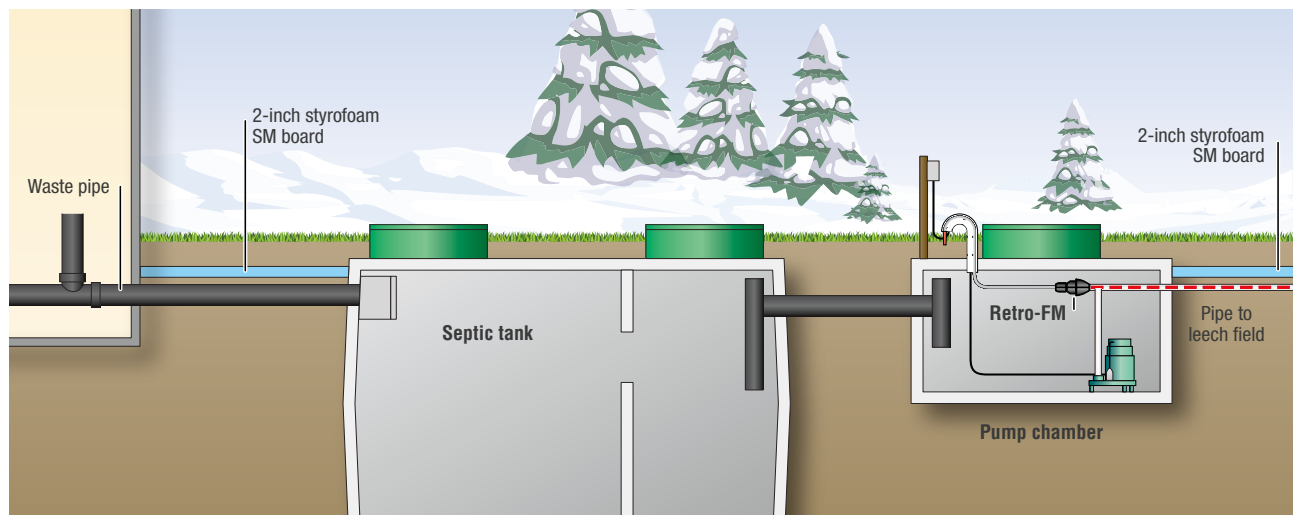

Rizer-Line

The preferred heating cable solution for preventing automatic water bowls from freezing.

Rizer-Line is a job-ready freeze protection kit designed to be installed with existing automatic water bowls to supply reliable and safe drinking water.



See more product information, videos, photos, technical documents, and more



Patents USA and Canada NSF/ANSI 61

Rizer-Line

Features & Benefits

- The only heating cable system designed specifically for automatic water bowls
- Plumbing fitting included – 1 inch MIPT thread
- Available in a plug-in GFCI model or hard wire cord-set model depending on application
- In-pipe length can be adjusted (shortened) on the job-site by means of extracting the cable through plumbing fitting
- Suitable for installation in pipe diameters ¾ inch and larger
- Suitable for installation in/on plastic and metal pipes
- Fully serviceable, can easily be removed if necessary
- Can be fully insulated to maximize energy efficiency
- Suitable for above ground applications with insulation
- Will never melt or overheat, even if pipe is dry
- Can be overlapped without concern of overheating
- Proven in -40°F weather above ground with ¾ inch polyethylene insulation

Specifications

- cCSAus approved (Canada and USA) LR85446
- NSF/ANSI 61 Drinking Water Safe
- Approved for potable drinking water
- Certified Usage Type P and X Canada
- Installation Type D USA
- Self-regulating/conductive polymer heating cable
- Fluoropolymer outer jacket
- Standard wattage 3 W/ft @ 50°F (10 W/m @ 10°C)
- Available in 120V and 240V
- 10 feet of in-pipe heater and 2 feet of on-pipe heater
- Available with either GFCI plug or CS hard wire connection
- Standard warranty of 5 yrs with optional 10 yrs

Applications

- Anywhere automatic livestock watering bowls require freeze protection

For more Features and Benefits common to all Heat-Line systems, refer to page 6.





Complete System

Rizer-Line is the preferred heating cable solution for preventing automatic water supply bowls from freezing.

All In One System

Rizer-Line is a complete kit designed to internally freeze protect the water supply pipe coming up to the bowl and externally freeze protect the small pipes within the bowl casing itself.

Safe For Livestock

Rizer-Line is safe to use in/on all pipe materials including plastic. The self-regulating technology ensures it will never overheat and melt. The GFCI prevents risk of shock to animals if the heating cable were to ever sustain damage.

CSA/NSF Approved

Rizer-Line has been through the strictest tests by CSA and NSF to prove it is safe to use in drinking water. We understand the animals deserve the best, clean water without harmful toxins.

Easy Installation

Simple, effective design for ease of installation. Supplied with everything you need to have the system operational; factory terminated heating cable, plumbing fitting and either choice of plug-in with GFCI or hardwire. Install 10 feet of heater inside the supply and the remain 2 feet on the external pipes and under the water bowl.

Will Not Overheat

Manufactured using North American self-regulating heating cable which adjusts its heat output based on surrounding temperatures. It can never overheat, even on plastic pipes or if the pipe is dry.

Requirements

Can interface into any supply pipe $\frac{3}{4}$ inch ID or larger and protect any size pipes or tubes within the bowl casing itself. Can be supplied in 120 or 240 volt. As a plug-in unit with GFCI protection or as a direct hard wire unit.

Fully Serviceable

The Rizer-Line can easily be removed and re-installed if ever necessary.

Emergency Systems

Can be installed as a precautionary system to only be energized if a freeze up occurs. It will easily, safely and quickly melt and clear frozen water pipes.

Energy Efficient

Complete product is rated at only 36 watts, self-regulating.



Rizer-Line | Product Code Guide

Example: **RL - 100 - 012FLG**

Product

RL 120 V Rizer-Line
RL2 240 V Rizer-Line

Thread Size

100 Male adapter MIPT fitting 1"

Cord-Set Type

FLG Ground fault protected
5-15 P 120 V / 6-15 P 240 V
FLC Cord connected (no GFCI)

Length of System

12 ft

NOTE: Nominal power output of Rizer-Line system is 3 W/ft @ 50°F (10 W/m @ 10°C). Only available in Drinking Water Safe Fluoropolymer outer heating cable jacket.

Rizer-Line | Accessories

HLJ-STAT 120V plug-in thermostat (GFC)
HLA-120 120V plug-in thermostat (GFC)
TIMER-120P 120V plug-in timer (GFC)
TIMER-240P 240V plug-in timer (GFC)
TIMER-CS 120/240V hard wire timer (CS)
MA-10 120/240V GFCI/ELCI (CS)
INSUL-1.00 Insulation sleeve for 1 inch ID pipe (1 5/8 inch ID, 6 ft long)

HLP-TAPE Tape for insulation sleeve butt joints (100 ft)
INSUL-FOIL Aluminum bubble foil insulation (16 in wide, sold by the foot)
INSUL-TAPE All weather aluminum foil tape (150 ft)
PLD-CG Cable guards/protectors (pkg of 4, 6 in each)
WARRANTY Extended 10 year limited warranty

Rizer-Line | Typical Cross Section

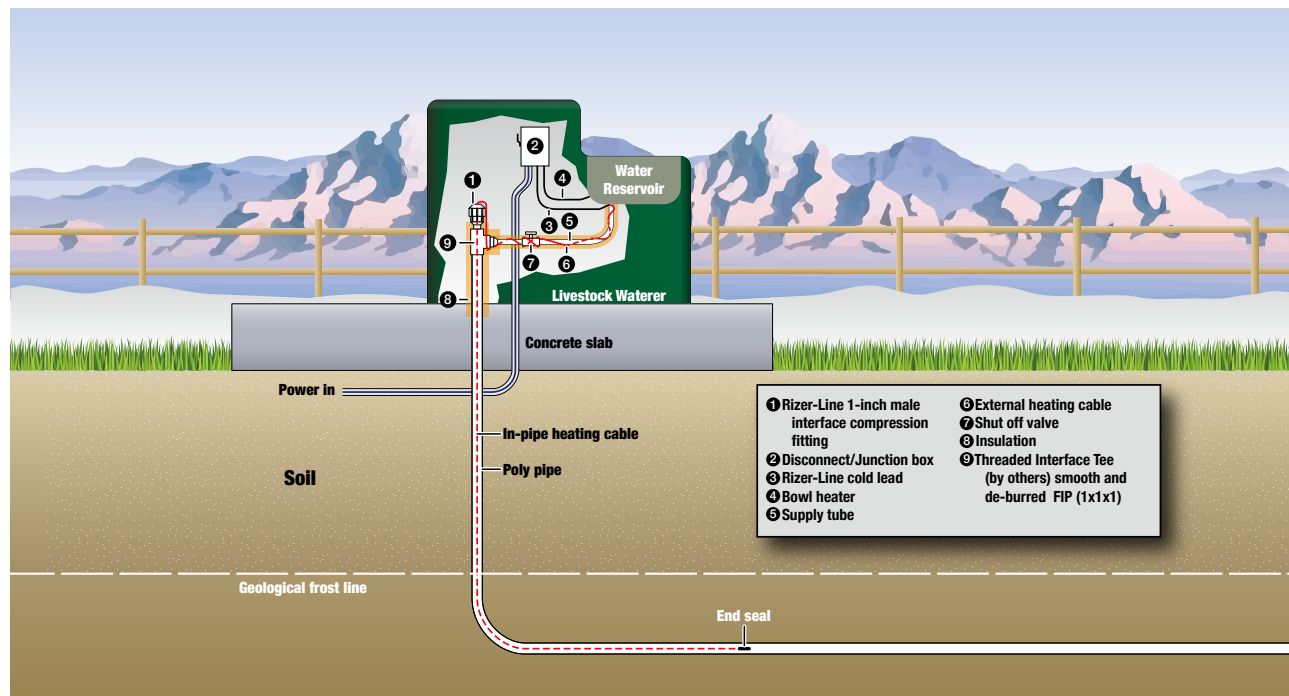

CARAPACE®

The Only Certified Rural and Municipal Freeze Protected Water Supply Pipe.

CARAPACE is a high performance, freeze protected (heated), HDPE polyethylene water pipe designed for use in municipal or domestic water supply and sewage force main applications.

Available as a complete job-ready system or on 1000 foot reels for field splicing and terminating.

**Insulation not included*



Job-Ready



SCAN ME

Cut-To-Length



SCAN ME

See more product information, videos, photos, technical documents, and more



Patents USA and Canada NSF/ANSI 61

CARAPACE

Features & Benefits

- The only certified rural and municipal freeze protected water supply pipe solution
- Unique construction provides superior heat transfer
- Approved for constant pressure systems
- Approved for direct earth burial and wet location
- Available factory finished, job-ready and tested prior to shipment
- Available cut-to-length for on-site field termination
- Available in a plug-in GFCI model or hard wire cord-set model depending on application
- Compatible with industry standard fittings
- Available in common lengths and long lengths
- Labour savings – no need to excavate below the frost line or blast rock
- Suitable for above ground applications with insulation
- Can be fully insulated to maximize energy efficiency
- Will never melt or overheat, even if pipe is dry
- Proven in -40°F weather above ground with ¾ inch polyethylene insulation

Redundancy

- CARAPACE can be used as a back-up system
- When pipes are installed on the fringe of the frost line or in critical areas under roadways etc.,
- CARAPACE can be energized if freezing occurs, restoring water flow in minutes while preventing the need for costly jetting or steaming of pipes

For more Features and Benefits common to all Heat-Line systems, refer to page 6.



Specifications

- cCSAus B137.1 approved (Canada and USA) LR85446
- cNSF 14-61 approved (Canada and USA)
- Approved for potable drinking water
- Certified Usage Type W Canada
- Installation Type A USA
- Self-regulating/conductive polymer heating cable
- Standard wattage 3 and 5 W/ft @ 50°F (16 W/m @ 10°C)
- Available in 120V and 240V
- Max lengths 120V - 240 ft, 240V - 660 ft
- Available with either GFCI plug or CS hard wire connection
- 1 inch ID (SIDR-9) and 1.25 inch ID (SIDR-9) 200PSI NSF STD 14 polyethylene
- 1 inch CTS (SODR-9) 250PSI NSF STD 14 polyethylene
- Constructed of PE 4710 Resin HDPE
- Standard warranty of 5 yrs with optional 10 yrs

Applications

- Frozen sites where water is required
- Residential water supply, municipal water supply
- Sewage force mains
- Whenever deep blasting would be required to reach frost line
- Floating docks, sea walls, bridge crossings
- Construction sites, mining/oil/gas sites (ordinary locations)
- Shallow trenches
- Remote camps
- Ground source heat pump headers





Unique, Patented Product

CARAPACE is a unique, patented product constructed of high density polyethylene pipe (HDPE) with a proprietary self-regulating heating cable extruded directly onto the outer surface of the pipe. The heating cable is then mechanically protected by a high density polyethylene outer jacket or shell, ensuring the conductive core of the heating cable remains in continuous contact with the pipe wall while protecting it from mechanical injury.

The special construction of CARAPACE provides superior thermal heat transfer and unsurpassed energy efficiency when combined with thermal insulation and a thermostat.

CARAPACE is available in two options depending on job requirements. CARAPACE can be supplied factory finished to a specified length with power and end terminations installed or as a cut-to-length product for field measuring and terminating.

Alternative to Excavating

CARAPACE is an excellent alternative to costly excavating and blasting of rock or wherever permanent or temporary reliable freeze protection is required. The durability and termination flexibility of CARAPACE renders it a suitable product for a vast variety of applications, including residential, agriculture, commercial, industrial, mining and exploration, remote camps and construction.

Direct Earth Burial

CARAPACE is a CSA B137.1, NSF 14-61 approved product constructed with high density PE 4710 polyethylene for potability and is approved for direct earth burial and free air installations.

CARAPACE Rural Grade is available in 120 volt and 240 volt and sized in SIDR (internal diameter), 200 PSI rated, high density polyethylene. CARAPACE Rural Grade 250 PSI rated is also available by special order.

CARAPACE Municipal Grade is available in 240 volt and sized in CTS (copper tube size), 250 PSI rated, high density polyethylene. 120 volt Municipal Grade is available by special order.

Pipe temperatures can be maintained using insulation and thermostatic control.

Municipal and Domestic Freeze Protection

CARAPACE is a high performance product designed to provide energy efficient and reliable municipal and domestic pipe freeze protection.

Eliminates Steaming or Jetting Out Pipes

CARAPACE can be used continuously through winter as freeze protection or as a precautionary system in problematic geographies. In this case, as freeze-maintenance on the fringe of the frost line, the system can simply be energized in the event of a freeze. Water will begin flowing within a short time, preventing and eliminating the costly expense and need to steam or jet out pipes.

CARAPACE | Product Code Guide

CARAPACE Job-Ready (Pre-Assembled)

Example: **CR2 – 5 – 125 – 100 – GFC**

Product		Cord-Set Type	
CR	120 V Rural CARAPACE	GFC	Ground fault protected
CR2	240 V Rural CARAPACE	5-15 P	120 V / 6-15 P 240 V
CM2	240 V Municipal CARAPACE	CS	Cord connected (no GFCI)
Nominal Power Output		Length of System	
3	3 W/ft @ 50°F (10 W/m @ 10°C)	GFC Ground Fault Protected	CS Cord Connected (no GFCI)
5	5 W/ft @ 50°F (16 W/m @ 10°C)	Max length	Max length
Pipe Size		3 W/ft 120 V	270 ft
100	Pipe size 1" CR(2) ID, SIDR 9 200 psi	5 W/ft 120 V	230 ft
	CM2 OD, CTS SODR 9 250 psi	3 W/ft 240 V	660 ft
125*	Pipe size 1 ¼" CR(2) ID, SIDR 9 200 psi	5 W/ft 240 V	540 ft

* Not available in CTS pipe size or 3 W/ft system

NOTE: For "CS" system installers must provide 20 Amp circuits for circuit lengths greater than 550 ft for 3 W/ft CARAPACE and 460 ft for 5 W/ft CARAPACE.

CARAPACE Rural and Municipal Cut-To-Length (Sold by the Foot)

Example: **RHPE – 5 – 125**

Product		Pipe Size	
RHPE	120 V Rural CARAPACE	100	Pipe size 1" RHPE(2) ID, SIDR 9 200 psi
RHPE2	240 V Rural CARAPACE		MHPE2 OD, CTS SODR 9 250 psi
MHPE2	240 V Municipal CARAPACE	125*	Pipe size 1 ¼" RHPE(2) ID, SIDR 9 200 psi
Nominal Power Output			
3	3 W/ft @ 50°F (10 W/m @ 10°C)		
5	5 W/ft @ 50°F (16 W/m @ 10°C)		

* Not available in CTS pipe size or 3 W/ft system

NOTE: Installers must provide 20 Amp circuits for circuit lengths greater than 550 ft for 3 W/ft CARAPACE and 460 ft for 5 W/ft CARAPACE.

CARAPACE | Accessories

HLJ-STAT	120V plug-in thermostat (GFC)	INSUL-1.25	Insulation sleeve for 1 ¼ inch ID pipe (1 7/8 inch ID, 6 ft long)
GFA-STAT	120/240V hard wire thermostat GFEP (CS)	INSUL-2.00	Insulation sleeve for 2 inch ID pipe (2 5/8 inch ID, 6 ft long)
TIMER-CS	120/240V hard wire timer (CS)	HLP-TAPE	Tape for insulation sleeve butt joints (100 ft)
MA-10	120/240V GFCI/ELCI (CS)	CR-CKIT	CARAPACE power and end seal kit
INSUL-1.00	Insulation sleeve for 1 inch ID pipe (1 5/8 inch ID, 6 ft long)	CR-CESS	CARAPACE end seal kit

Heat-Line®

Advanced Internal Water Supply Pipe System.

Heat-Line is a complete pipe system supplied with the Retro-Line heating cable system factory installed inside a 75 PSI, CSA approved polyethylene water pipe for new pipe installations.



75 PSI Certified
Polyethylene Pipe



Retro-Line



Heat-Line



See more product information, videos,
photos, technical documents, and more



Patents USA and Canada

NSF/ANSI 61

Heat-Line

Features & Benefits

- The only manufactured, self-regulating heating cable factory installed in pipe
- Available in 1 inch ID and 1¼ inch ID, 75 PSI polyethylene pipe
- Available in a plug-in GFCI model or hard wire cord-set model depending on application
- Customizable for various application requirements
- Length of heating cable can be adjusted (shortened) on the job-site by means of extracting the cable through plumbing fitting
- Available in common lengths and long lengths
- Heating cable is rigid enough to stay in place within the entire length of pipe
- Labour savings – no need to excavate below the frost line or blast rock
- Fully serviceable, can easily be removed if necessary
- Will never melt or overheat, even if pipe is dry
- Proven in -40°F weather above ground with ¾ inch polyethylene insulation

For more Features and Benefits common to all Heat-Line systems, refer to page 6.

Specifications

- cCSAus approved (Canada and USA) LR85446
- Approved for potable drinking water
- Certified Usage Type P Canada
- Installation Type A USA
- Self-regulating/conductive polymer heating cable
- Fluoropolymer outer jacket
- Standard wattage 3 W/ft @ 50°F (10 W/m @ 10°C), special wattage available
- Available in 120V and 240V
- Max lengths 120V - 230 ft, 240V – 300 ft
- Available with either GFCI plug or CS hard wire connection
- Engineered proprietary end seal technology
- Standard warranty of 5 yrs with optional 10 yrs

Applications

- New water supply lines requiring freeze protection
- Potable water supply 75 PSI or less
- Rural home and business water supply lines
- Lake homes and cottages/cabins
- Lake/river water source
- Wells
- Farms, agriculture





Complete Freeze Protected Polyethylene Pipe System

The Heat-Line system is supplied in a pre-determined length with the self-regulating heating cable already installed inside 75 PSI, CSA approved polyethylene pipe. Philmac plumbing fitting also supplied.

Easy Installation

Just unroll the pipe and interface to plumbing fittings as necessary as you would with any non-heated poly.

Reliable Above Ground

Heat-Line has been proven to keep water from freezing in -40°C/F when installed above ground with ¾ inch thick pipe insulation. No need to blast rock to bury the pipe.

Energy Efficient

Save up to 80% in energy consumption when combining thermostats and insulation. Thermostat and timers are optional with Heat-Line. They can be used to duty cycle the heating cable in an on/off operation making it more energy efficient. Heat-Line is safe to insulate and will make the heating cable operate more efficiently and reliably when used.

Requirements

Heat-Line orders require the length of system and size of pipe. Maximum system length in 240 volt is 300 feet.

Emergency Systems

In many applications Heat-Line is ordered for new builds where the water system is not yet complete. Heat-Line is ordered with insulation and installed on the ground until the following year where the trench can be dug and the same Heat-Line system buried.

Energy Efficient

With its self-regulating heating cable. Heat-Line has the ability to be the most energy efficient heating cable available, providing you insulate and add a thermostat.

Fully Serviceable

The Heat-Line system is a fully serviceable product. Should you need to remove the heating cable, simply remove the plumbing tee fitting and pull out the heating cable.

Customizable

In many cases custom lengths can be ordered such as 80 feet of heating cable installed inside 100 feet of pipe.

Heat-Line | Product Code Guide

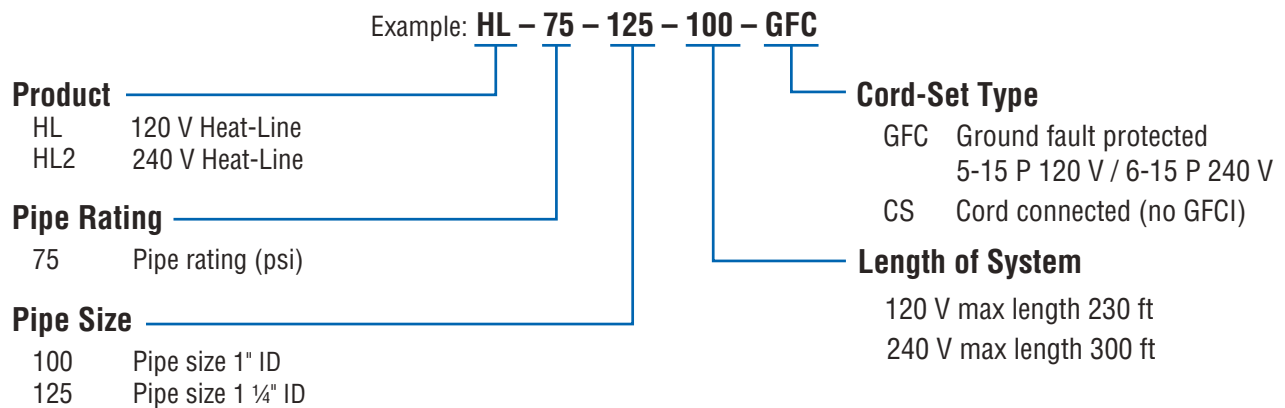

NOTE: Nominal power output of Heat-Line system is 3 W/ft @ 50°F (10 W/m @ 10°C). Only available in Drinking Water Safe Fluoropolymer outer heating cable jacket.

Heat-Line | Accessories

HLJ-STAT	120V plug-in thermostat (GFC)	MA-10	120/240V GFCI/ELCI (CS)
HLA-120	120V plug-in thermostat (GFC)	INSUL-1.00	Insulation sleeve for 1 inch ID pipe (1 5/8 inch ID, 6 ft long)
GFA-STAT	120/240V hard wire thermostat GFEP (CS)	INSUL-1.25	Insulation sleeve for 1 ¼ inch ID pipe (1 7/8 inch ID, 6 ft long)
TIMER-120P	120V plug-in timer (GFC)	HLP-TAPE	Tape for insulation sleeve butt joints (100 ft)
TIMER-240P	240V plug-in timer (GFC)	WARRANTY	Extended 10 year limited warranty
TIMER-CS	120/240V hard wire timer (CS)		

Heat-Line | Typical Cross Section

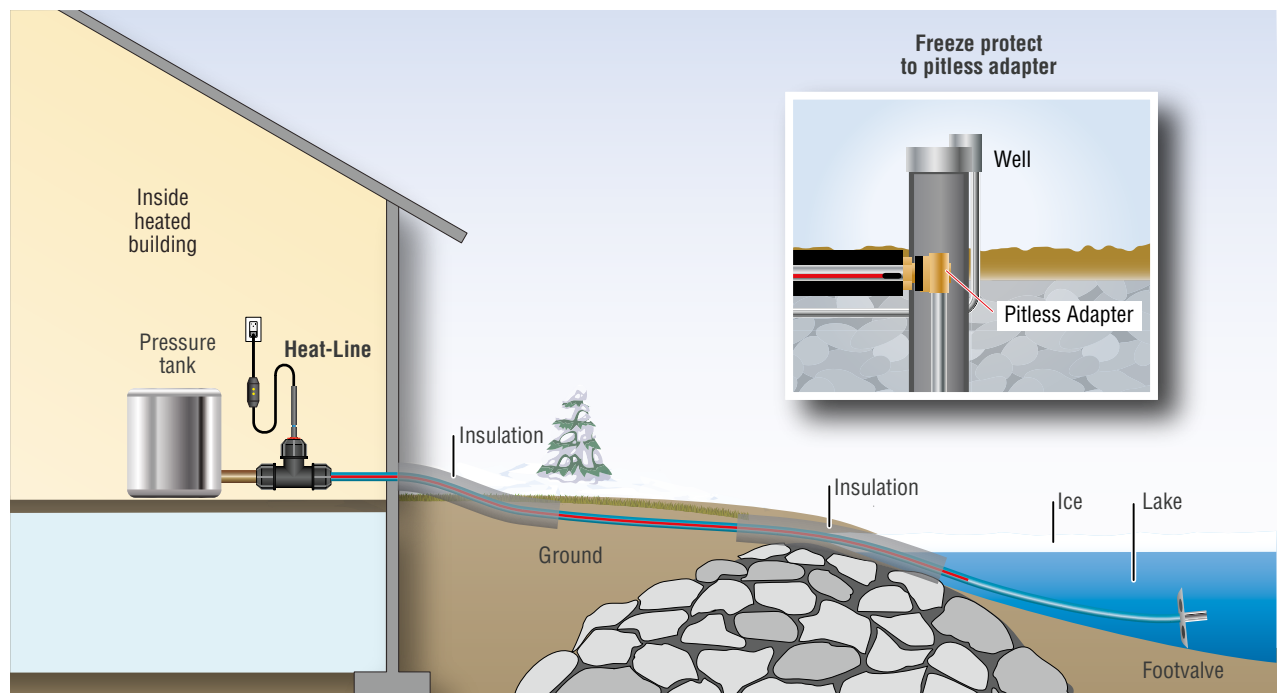

Paladin[®]/EXT

Multi-Use Freeze Protection for Pipes, Tanks and Vessels of All Types and Sizes.

Paladin/EXT Series is a job-ready freeze protection kit for use on both metal and plastic pipes. Paladin is acceptable for direct earth burial and wet location, making it suitable to be installed inside non-pressurized, non-potable pipes such as drainage pipes.



Paladin



SCAN ME

EXT-R Series



SCAN ME

EXT-T Series



SCAN ME

See more product information, videos, photos, technical documents, and more



Paladin/EXT Series

Features & Benefits

- Suitable for direct earth burial and wet location
- Factory finished to length making installation simple, fast and cost effective
- Available in a plug-in GFCI model or hard wire cord-set model depending on application
- Customizable for various application requirements
- Available in common lengths and long lengths
- Suitable for multiple pipe sizes both metal and plastic
- Lengths of EXT in 40 feet and greater are supplied on a dispensing reel for ease of installation
- Will never melt or overheat, even if pipe is dry
- Can be overlapped without concern of overheating
- Can be used to protect, pipes, tanks, vessels, soil heating and more
- Can be installed inside non-pressurized drain pipes
- Approved for applications with aggressive fluids or materials (EXT-T)
- Single trace installation is suitable for most applications saving product length

For more Features and Benefits common to all Heat-Line systems, refer to page 6.



Specifications

- cCSAus approved (Canada and USA) LR85446
- Certified Usage W and S (Paladin only) Canada
- Installation Type A USA
- Approved for direct burial and wet location
- Self-regulating/conductive polymer heating cable
- Thermo Plastic Elastomer (TPE) jacket (Paladin and EXT-R)
- Fluoropolymer outer jacket (EXT-T)
- Standard wattage 5 W/ft @ 50°F (16 W/m @ 10°C)
- Special wattages available
- Available in 120V and 240V
- Max lengths 120V - 230 ft, 240V - 550 ft
- Available with either GFCI plug or CS hard wire connection
- Standard warranty of 5 yrs with optional 10 yrs
- Suitable for exposure temperatures up to 150°F (65°C)

Applications

- Existing water supply lines subject to freezing
- Small diameter water supply lines
- Large diameter pipes
- Sewage pipes, drains and culverts
- All metal pipes, all plastic pipes
- Metal tanks, Non-metal tanks
- Lake homes and cottages, farms, agriculture
- Commercial, industrial, construction sites
- Camps, mining
- Soil heating
- Food processing plants (EXT-T)
- Parking garages





Paladin vs EXT-R vs EXT-T

There is no mechanical and or physical difference between the Paladin and EXT-R series product groups. However, the Paladin system carries an additional certification designation which makes it certified for use in roof and gutter applications. These designations restrict the maximum product length allowed so to allow for longer pipe heat tracing systems we drop the Roof and Gutter designations and use the EXT-R product name.

The EXT-T heating cable is constructed with a fluoropolymer outer jacket resistant to aggressive fluids and or materials, such as animal urine, manure, gasolines and oils. The fluoropolymer jacket also has potability ratings so is suitable for certain food processing plant applications. In comparison, the EXT-R and Paladin heating cables are constructed with an elastomeric outer jacket design for ordinary installations. Apart from the cable jacket material, another difference is the standard wattage available.

Practical and Versatile External Systems

Paladin/EXT is designed to be applied to the outside of the pipe, making it suitable for both small and large pipe diameters. Traditional style heat tapes must be pitched or spiraled around the pipes in order to apply an adequate amount of heat, making them very high in energy consumption. In most applications, the Paladin/EXT systems are installed in a single run, reducing the overall length of product by as much as 60 percent. For large pipe diameters or where more heat is required, a dual (double) trace system is adequate, which still saves on product length.

CSA Approved

Paladin/EXT carries CSA approvals for wet location and direct earth burial which is not found on any other external heating cable on the market.

The wet location approval allows the heating cable to be installed inside non-pressurized, non-potable, non-metallic or metallic pipes such as drains and culverts, making installation easy for pre-buried pipes. Direct earth burial allows installation on the outside of water supply lines and septic pipes before they are buried.

Versatile Applications

The Paladin/EXT systems are so versatile that they are used in a variety of applications, including but not limited to water supply lines such as lake/river to house, well to house, building to building, farm water or fluid supply, RV and marine water supply as well as under structure copper pipes, any exposed pipes, culverts, drains, tanks and even in some soil heating applications.

Safe on All Pipe Materials

Paladin/EXT is safe to use on all pipe materials, including plastic and metals, even if there is no water in the pipe. Insulation and a thermostat can be added to the system to further optimize energy efficiency.

Factory Finished

Paladin/EXT is factory finished to length making installation simple, fast and cost effective. The need for an electrician to provide on-site power and complex terminations is eliminated.

Paladin | Product Code Guide

Example: **PLDI – 100 – GFC**

Product

PLDI	120 V Paladin
PLDI2	240 V Paladin

Cord-Set Type

GFC	Ground fault protected 5-15 P 120 V / 6-15 P 240 V
CS	Cord connected (no GFCI)

Length of System

120 V max length	120 ft
240 V max length	240 ft

NOTE: Nominal power output of Paladin system is 5 W/ft @ 50°F (16 W/m @ 10°C). Only available in Modified Polyolefin outer heating cable jacket.

EXT Series | Product Code Guide

Example: **EXT120 – 5 – R – 100 – GFC**

Product

EXT	External Heating Cable
-----	------------------------

Voltage

120	120 V EXT
240	240 V EXT

Nominal Power Output

3	3 W/ft @ 50°F (10 W/m @ 10°C)
5	5 W/ft @ 50°F (16 W/m @ 10°C)
8	8 W/ft @ 50°F (26 W/m @ 10°C)

Heater Type

R	Modified Polyolefin heater jacket
T	Fluoropolymer heater jacket

Cord-Set Type

GFC	Ground fault protected 5-15 P 120 V / 6-15 P 240 V
CS	Cord connected (no GFCI)

Length of System

	GFC Ground Fault Protected	CS Cord Connected (no GFCI)
	Max length	Max length
3 W/ft 120 V	270 ft	300 ft
5 W/ft 120 V	230 ft	270 ft
8 W/ft 120 V	150 ft	200 ft
3 W/ft 240 V	550 ft	660 ft
5 W/ft 240 V	460 ft	540 ft
8 W/ft 240 V	300 ft	400 ft

NOTE: Installers must provide 20 Amp circuits for CS circuit lengths greater than the maximum length set for GFC.

Paladin/EXT Series | Accessories

HLJ-STAT	120V plug-in thermostat (GFC)	INSUL-2.00	Insulation sleeve for 2 inch ID pipe (2 5/8 inch ID, 6 ft long)
HLA-120	120V plug-in thermostat (GFC)	INSUL-3.00	Insulation sleeve for 3 inch ID pipe (3 1/2 inch ID, 6 ft long)
GFA-STAT	120/240V hard wire thermostat GFEP (CS)	INSUL-4.00	Insulation sleeve for 4 inch ID pipe (4 1/2 inch ID, 6 ft long)
TIMER-120P	120V plug-in timer (GFC)	HLP-TAPE	Tape for insulation sleeve butt joints (100 ft)
TIMER-240P	240V plug-in timer (GFC)	INSUL-FOIL	Aluminum bubble foil insulation (16 in wide, sold by the foot)
TIMER-CS	120/240V hard wire timer (CS)	INSUL-TAPE	All weather aluminum foil tape (150 ft)
MA-10	120/240V GFCI/ELCI (CS)	PLD-CG	Cable guards/protectors (pkg of 4, 6 in each)
INSUL-1.00	Insulation sleeve for 1 inch ID pipe (1 5/8 inch ID, 6 ft long)	WARRANTY	Extended 10 year limited warranty
INSUL-1.25	Insulation sleeve for 1 1/4 inch ID pipe (1 7/8 inch ID, 6 ft long)		

Tandem-Link

Wet Location Inter-Connecting Freeze Protection Systems.

Tandem-Link units are watertight job-ready heating cable systems that plug directly into one another, allowing on site length flexibility.



See more product information, videos, photos, technical documents, and more



Tandem-Link

Features & Benefits

- The only inter-connecting heating cable product available
- Available in a plug-in GFCI model or plug-in no GFCI depending on application
- Can use up to 3 units to adjust length as required
- Can be used as permanent or temporary installation
- Watertight connection system allows rapid installation/removal/re-use
- Investment protection – segments are re-usable
- Simply disconnect, store and re-use
- Available in common lengths and long lengths
- Suitable for multiple pipe sizes both metal and plastic
- Will never melt or overheat, even if pipe is dry
- Can be overlapped without concern of overheating
- Can be used to protect, pipes, tanks, vessels and more
- Factory finished, job-ready – no liability for installer
- Installation is simple, fast and cost effective
- Single trace installation is suitable for most applications saving product length

Specifications

- cCSAus approved (Canada and USA) LR85446
- Certified Usage W Canada
- Installation Type A USA
- Certified for damp locations
- Self-regulating/conductive polymer heating cable
- Thermo Plastic Elastomer (TPE) jacket
- Standard wattage 5 W/ft @ 50°F (16 W/m @ 10°C)
- Available in 120V and 240V
- Max lengths 120V - 205 ft, 240V - 410 ft
- Available with either GFCI plug or regular plug for field GFCI installation
- Wetguard male and female plug ends certified for wet location NEMA Type 4, 4X, 6, 6P
- Maximum 3 connected cables and/or maximum length per voltage
- Standard warranty of 5 yrs
- Suitable for exposure temperatures up to 150°F (65°C)

Applications

- Anywhere temporary water or non-flammable fluid pipes are exposed to freezing

For more Features and Benefits common to all Heat-Line systems, refer to page 6.





Inter-Connecting Systems

Temporary wet location inter-connecting freeze protection systems.

Factory Finished, Job Ready

Tandem-Link systems are factory finished, job-ready heating cable systems that plug directly into one another, allowing on site length flexibility without the requirement of an electrician for field splicing and terminating in extreme climate conditions.

Self-Regulating

Tandem-Link systems are self-regulating, making them safe for use on all pipe materials, which may or may not always be filled with fluid. Insulation can always be added to increase efficiency and allow operation even in the harshest environments.

Wet Location Certified

Tandem-Link systems are supplied with quality, durable, wet location certified plug and receptacle connections.

Cold Weather Reliability

Tandem-Link systems are suitable for many applications, including cold weather construction requiring permanent or temporary water or fluid pipe heating. If used in a temporary application, the Tandem-Link system can be simply unplugged, rolled up and stored until it is required again for the next project.

CSA Approved

CSA approved for wet location.

Maximum 3 connected cables and

- 120 volt maximum connected length 205 feet
- 240 volt maximum connected length 410 feet

Practical Installation

Tandem-Link is designed to be applied to the outside of the pipe, making it suitable for both small and large pipe diameters. Traditional style heat tapes must be pitched or spiraled around the pipes in order to apply an adequate amount of heat, making them very high in energy consumption.

In most applications, the Tandem-Link systems are installed in a single run, reducing the overall length of product by as much as 60 percent. For large pipe diameters or where more heat is required, a dual (double) trace system is adequate, which still saves on product length.

Safe on All Pipe Materials

Tandem-Link is safe to use on all pipe materials, including plastic and metals, even if there is no water in the pipe. Insulation and a thermostat can be added to the system to further optimize energy efficiency.

Tandem-Link | Product Code Guide

		Example: TL2 - 50 - CS	
Product	TL	120 V Tandem-Link	Cord-Set Type
	TL2	240 V Tandem-Link	
			CS Cord connected (no GFCI)
			Length of System
		120 V	max connected length 205 ft
		240 V	max connected length 410 ft

NOTE: Nominal power output of Tandem-Link system is 5 W/ft @ 50°F (16 W/m @ 10°C). Only available in Modified Polyolefin outer heating cable jacket.

Tandem-Link | Accessories

HLJ-STAT	120V plug-in thermostat (GFC)	INSUL-2.00	Insulation sleeve for 2 inch ID pipe (2 5/8 inch ID, 6 ft long)
HLA-120	120V plug-in thermostat (GFC)	INSUL-3.00	Insulation sleeve for 3 inch ID pipe (3 1/2 inch ID, 6 ft long)
GFA-STAT	120/240V hard wire thermostat GFEP (CS)	INSUL-4.00	Insulation sleeve for 4 inch ID pipe (4 1/2 inch ID, 6 ft long)
TIMER-120P	120V plug-in timer (GFC)	HLP-TAPE	Tape for insulation sleeve butt joints (100 ft)
TIMER-240P	240V plug-in timer (GFC)	INSUL-FOIL	Aluminum bubble foil insulation (16 in wide, sold by the foot)
TIMER-CS	120/240V hard wire timer (CS)	INSUL-TAPE	All weather aluminum foil tape (150 ft)
MA-10	120/240V GFCI/ELCI (CS)	PLD-CG	Cable guards/protectors (pkg of 4, 6 in each)
INSUL-1.00	Insulation sleeve for 1 inch ID pipe (1 5/8 inch ID, 6 ft long)		
INSUL-1.25	Insulation sleeve for 1 1/4 inch ID pipe (1 7/8 inch ID, 6 ft long)		

Tandem-Link | Typical (120 Volt) Application

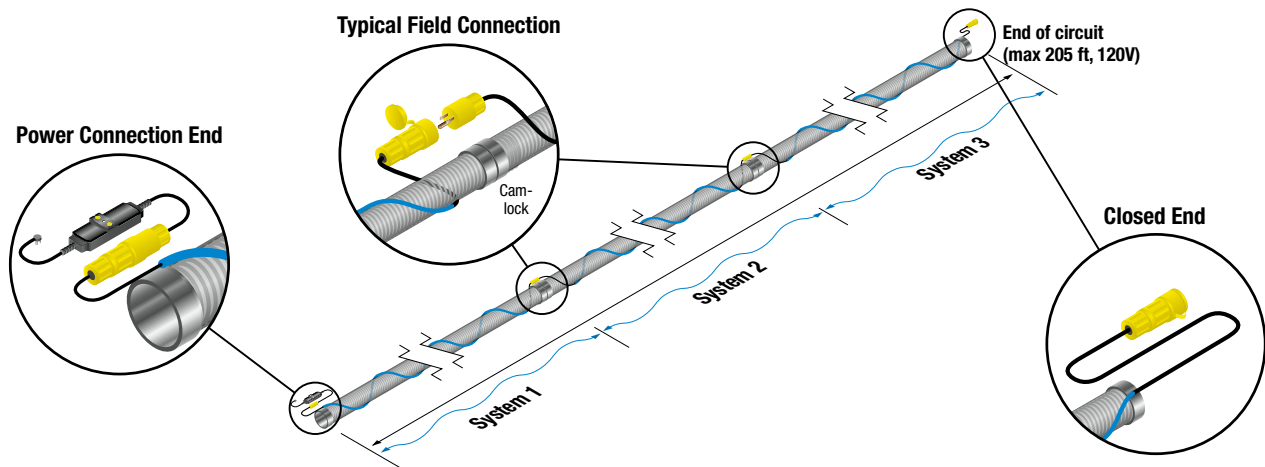

Kompensator®

Low Voltage Custom Manufactured Pipe Freeze Protection made to Suit Various Applications.

Kompensator systems are low voltage heating cables which are used in freeze protection applications for both metallic and non-metallic pipes, tubes, and hoses. These high quality heating cables are designed to be used in a variety of freeze protection applications including the transportation industry and are compatible with off-grid (solar and wind) and battery/alternator systems.



See more product information, videos, photos, technical documents, and more

Kompensator

Features & Benefits

- The only job-ready low voltage heating cable system available
- Factory finished, job-ready – minimized liability for installer
- Each finished system is tested prior to shipment
- Manufactured to finished lengths for individual service requirements
- Customizable for various application requirements
- Compatible with DC and AC voltages
- Compatible with off-grid (solar and wind) and alternator battery generators
- Compatible with various methods of power generation including battery alternators
- Can be directly connected to alternator systems without need of inverters
- Continuous ground path
- Suitable for multiple pipe sizes both metal and plastic
- Can be fully insulated to maximize energy efficiency
- Thermostat is an available option
- Will never melt or overheat, even if pipe is dry
- Can be used to protect, pipes, hoses and more
- Suitable for direct burial and wet location
- Can be overlapped without concern of overheating
- Intended for ordinary locations only

For more Features and Benefits common to all Heat-Line systems, refer to page 6.



Specifications

- Low voltage heating cable
- Self-regulating/conductive polymer heating cable
- Thermo Plastic Elastomer (TPE) jacket
- Standard wattage 3 W/ft @ 50°F (10 W/m @ 10°C) and 5 W/ft @ 50°F (16 W/m @ 10°C)
- Available in 12V and 24V
- Max lengths 12V - 40 ft, 24V - 60 ft
- Supplied with 6 ft supply cord for direct hard wire connection
- Standard warranty of 1 yr
- Suitable for exposure temperatures up to 150°F (65°C)

Applications

- Transportation industry including fire and fluid delivery trucks
- Hydraulic and condensate fluid lines
- Existing water supply lines subject to freezing
- Small diameter water supply lines
- Large diameter pipes
- All metal and plastic pipes
- Rubber and PVC Hoses
- Metal tanks
- Non-metal tanks
- Farms, agriculture
- Commercial, industrial
- Camps
- Mining



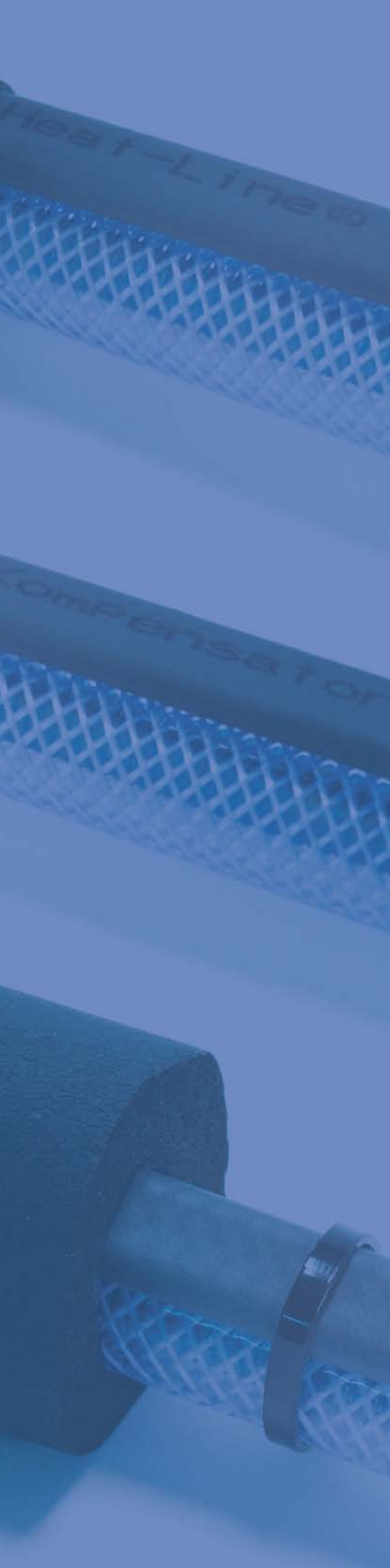

Job Ready System

Kompensator systems are the only low voltage, factory finished, job-ready heating cable systems that are designed to provide safe, efficient and reliable freeze protection.

Applied to Outside of Pipe

Kompensator is designed to be applied to the outside of the pipe, making it suitable for both small and large pipe diameters. Traditional heat tapes must be pitched or spiraled around the pipes in order to apply an adequate amount of heat, making them very high in energy consumption.

Install in Single Run

In most applications, the Kompensator system is installed in a single run, reducing the overall length of product by as much as 60 percent. For large pipe diameters or where more heat is required, a dual (double) trace system is adequate, which still saves on product length.

Oil Lines, Pumps, Hoses

The Kompensator system is so versatile that it can be used in a variety of applications where 12 and or 24 volt power is available, including but not limited to, small diameter hoses, appliance and comfort heating, condensate freeze protection, oil lines, hydraulic hoses, pumps and compressed air systems.

Transportation Industry

When used in the recreational vehicle and transportation industry, Kompensator systems are capable of maintaining hydraulic oil and other fluid viscosities in cold temperatures, minimizing stress while maximizing winter performance.

Safe on Plastic and Metal

Kompensator is safe to use on all pipe and hose materials, including plastic and metals, even if there is no water in the pipe. Insulation and a thermostat can be added to the system to further optimize energy efficiency. Heat-Line offers a low voltage thermostat option which can be used to duty cycle and regulate the heating cable system within a specific temperature range.

Simple, Fast, Cost Effective

Kompensator is factory finished to length and provided with a complete set of installation instructions making installation simple, fast and cost effective.

Customizable

Kompensator is a common OEM product completely customized for specific applications. Even single orders can easily be customized without time delay.

Kompensator | Product Code Guide

Example: **KHL123-040-CS**

Product

KHL123	12 V Kompensator 3 W/ft @ 50°F (10 W/m @ 10°C)
KHL125	12 V Kompensator 5 W/ft @ 50°F (16 W/m @ 10°C)
KHL243	24 V Kompensator 3 W/ft @ 50°F (10 W/m @ 10°C)
KHL245	24 V Kompensator 5 W/ft @ 50°F (16 W/m @ 10°C)

Cord-Set Type

CS Cord connected (No GFCI)

Length of System

3 W/ft 12 V max length 40 ft
 5 W/ft 12 V max length 30 ft
 3 W/ft 24 V max length 60 ft
 5 W/ft 24 V max length 40 ft

NOTE: It is the requirement of the installer to provide proper voltage regulation and over-current protection. It is also the recommendation of Heat-Line that since the power consumption of the product can never be 0 to install a shut-off switch to prevent the draining of batteries or power supply. Only available in Modified Polyolefin outer heating cable jacket.

Kompensator | Accessories

KHJ-STAT-2	6/28V thermostat	INSUL-PAD	Elastometric flexible insulation (10 ft long, 6 inch wide, ½ inch thick)
INSUL-1.00	Insulation sleeve for 1 inch ID pipe (1 5/8 inch ID, 6 ft long)	HLP-TAPE	Tape for insulation sleeve butt joints (100 ft)
INSUL-1.25	Insulation sleeve for 1 ¼ inch ID pipe (1 7/8 inch ID, 6 ft long)	INSUL-FOIL	Aluminum bubble foil insulation (16 in wide, sold by the foot)
INSUL-2.00	Insulation sleeve for 2 inch ID pipe (2 5/8 inch ID, 6 ft long)	INSUL-TAPE	All weather aluminum foil tape (150 ft)
		PLD-CG	Cable guards/protectors (pkg of 4, 6 in each)

Kompensator | Sample Application on Water Hauler Gate Valve

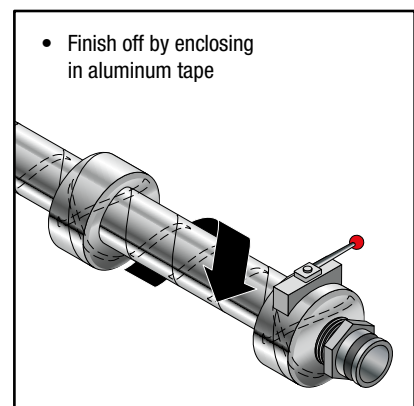
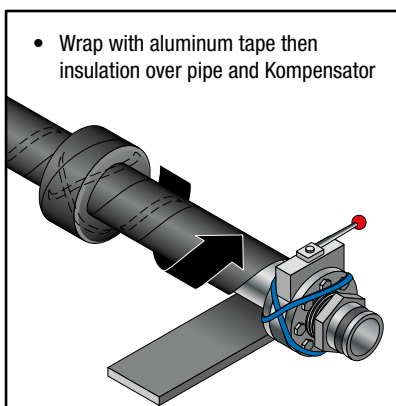
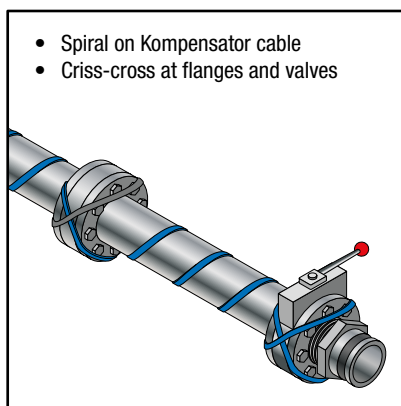

Paladin® for Roof

Award Winning Self-Regulating Heating Cable System Used for Many Roof and Gutter De-icing Applications.

Paladin is an exceptional freeze protection system for roof-de-icing and can be used on many different roof types and applications. Roof edge ice build-up, eave icing, icicles and ice dams can all be easily eliminated.



**Roof clips not included*



See more product information, videos, photos, technical documents, and more



Paladin for Roof

Features & Benefits

- The most reliable roof and gutter system available
- Available in a plug-in GFCI model or hard wire cord-set model depending on application
- Customizable for various application requirements
- Provides reliable roof and gutter freeze protection
- Compatible with a variety of roofing materials with various roofing materials including asphalt shingles, shakes, rubber, tar, wood, metal, and or plastic
- Can be used to effectively and efficiently heat trace around any skylight and or dormer windows
- Designed to be compatible with metal and plastic gutter and downspouts
- Easily and quickly installed on most roofs by means of roof clips or EDGE-CUTTER
- Will never melt or burn through plastic material, even if dry
- Can be used with a variety of control devices including snow controls, timers and thermostats

Specifications

- cCSAus approved (Canada and USA) LR85446
- Certified Usage W and S Canada
- Installation Type A USA
- Self-regulating/conductive polymer heating cable
- Thermo Plastic Elastomer (TPE) jacket
- Standard wattage 5 W/ft @ 50°F (16 W/m @ 10°C)
- Available in 120V and 240V
- Max lengths 120V - 120 ft, 240V - 240 ft
- Available with either GFCI plug or CS hard wire connection
- Standard warranty of 5 yrs with optional 10 yrs

Applications

- Suitable for asphalt shingles, aluminum, steel, and even slate
- Gutters, downspouts, drains
- Pitched roofs and flat roofs
- Residential roof applications
- Farms, agriculture
- Commercial, industrial
- Camps
- Mining





Multiple Design Options

When considering the Paladin for Roof system, Heat-Line can provide design ideas and important information regarding various application challenges. For standard gutter installations you install 1 foot of cable per foot of gutter and downspout. If the downspout is in the middle of the run, loop the Paladin down and back up, there is no concern of the Paladin system overheating if it comes into contact with itself. Double the length of the downspout for determining the length of Paladin to install. For valleys, run the heating cable two thirds of the way up and down the valley.

Cottage, Home, Resort

Paladin can be used in a variety of applications including, cottages, homes, resorts and farms. Snow sensors, thermostats, timers or other approved devices can be added to the system for increased energy efficiency.

Accessories

Heat-Line offers multiple accessories to compliment your Paladin heating cable such as roof clips, cable guards, downspout hanger brackets and of course Heat-Line's own EDGE-CUTTER roof de-icing system.

Control Devices

Heat-Line offers a variety of control devices to help your Paladin heat cable perform to its optimal, energy efficiency ability. Heat-Line offers timers, snow sensors, gutter ice sensors and more.

Quality, Reliability, Longevity

With Paladin you are getting the quality, reliability and longevity you would expect with a Heat-Line brand system. Not the nightmares you may expect with the common hardware store heat tapes.

Certification

Paladin is fully cCSAus certified for usage W and S (Canada), installation Type A (USA) for roof and gutter de-icing applications.

Conventional and Flat Roof De-Icing

Paladin is an exceptional freeze protection system designed for use on many different roof types and materials. It can be installed in a conventional serpentine configuration using roof clips or for a more aesthetically pleasing option it can also be combined with the Heat-Line EDGE-CUTTER channel flashings system. Either option will provide reliability and energy efficiency. Paladin is also suitable for flat roof applications as it will provide melt water paths towards the drains and even down the drain pipes.

Gutter, Downspout and Drain De-Icing

Paladin is fully certified to trace inside gutters, downspouts and remarkably even into the drain pipes themselves. Paladin carries the unique wet location approval due to Heat-Line's advanced boot end seal technology. This allows the heating cable to safely and reliability trace inside the drain pipes until the pipe exists the ground or natural frost protection is achieved.

Paladin for Roof | Product Code Guide

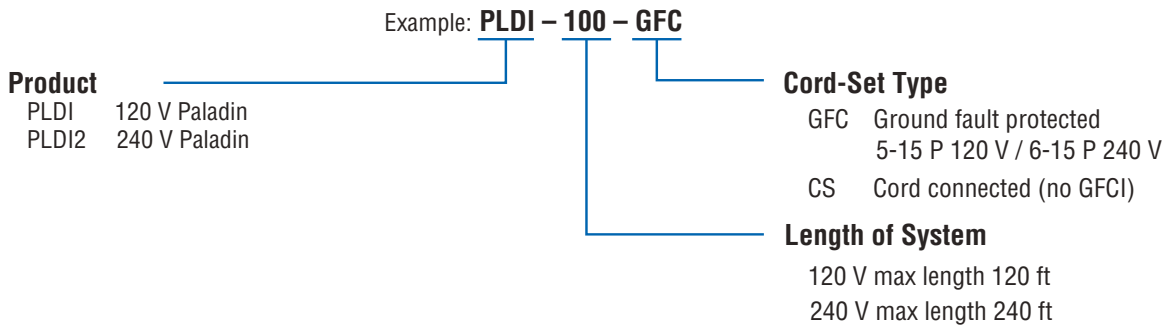

NOTE: Nominal power output of Paladin system is 5 W/ft @ 50°F (16 W/m @ 10°C). Only available in Modified Polyolefin outer heating cable jacket.

Paladin for Roof | Accessories

TIMER-120P	120V plug-in timer (GFC)	SNOW-OWL	Aerial snow sensor (requires controller, PD-PRO or GF-PRO)
TIMER-240P	240V plug-in timer (GFC)	LCD-8	Configurable snow switch controller
TIMER-CS	120/240V hard wire timer (CS)	PD-PRO	Snow/ice controller
MA-10	120/240V GFCI/ELCI (CS)	GF-PRO	Snow/ice controller with GFEP
PLD-CG	Cable guards/protectors (pkg of 4, 6 in each)	DS-8C-CONTROLLER	Rain/Snow Sensor Controller c/w Remote 10' Sensor
PLD-RC	Roof clips (package of 10)	DS-8C-EX-50	Rain/Snow Sensor Extension 50' Kit for DS-8C
PLD-EC	EDGE-CUTTER to suit (refer to page 51)	WARRANTY	Extended 10 year limited warranty
PLD-RDK	Downspout hanger kit		
GIT-1	Gutter ice sensor (requires controller, PD-PRO or GF-PRO)		

Paladin for Roof | Sample Application

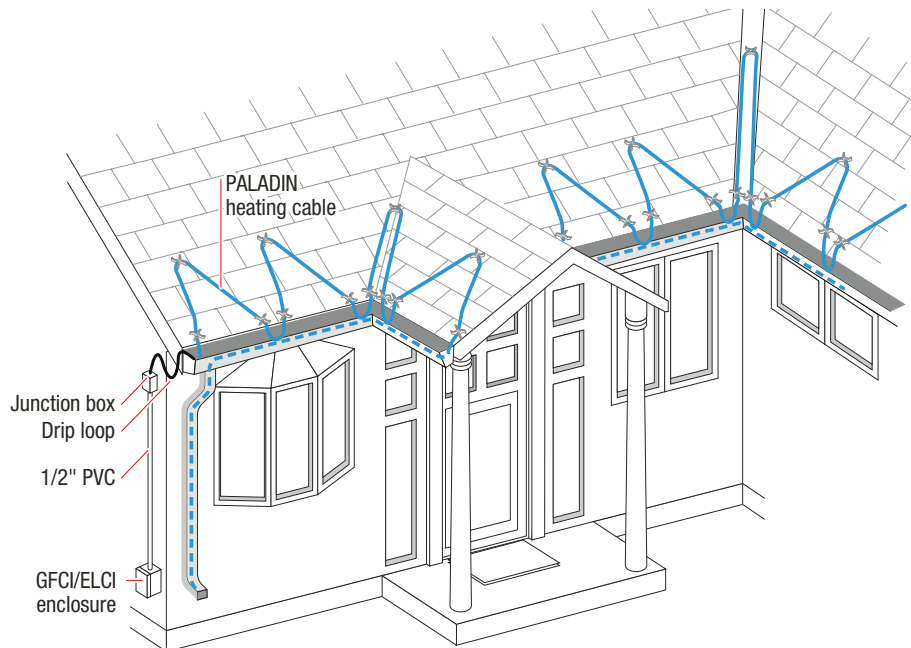

EDGE-CUTTER®

Aesthetically Pleasing Aluminum Channel Flashings Designed for Advance Roof De-icing Applications.

EDGE-CUTTER channels flashing are designed to prevent ice build-up, icicles, or ice dams on the leading roof edge and troublesome roof valley areas. EDGE-CUTTER is engineered to be used with a variety of different roofing materials such as asphalt shingles, aluminum, steel, and even slate.



SCAN ME

See more product information, videos, photos, technical documents, and more

EDGE-CUTTER

Features & Benefits

- 4 foot feathered aluminum flashing complete with cap
- Flat and Angled flashing available to suit various application requirements
- Provides a mechanically protected channel for heating cable
- Vastly reduces total amount of heating cable required by as much as 75%
- Fast, easy installation
- Can be cut for customization on the job-site
- Can be used under all roofing materials including metal, asphalt and slate
- For new or existing roofs
- Aesthetically pleasing
- Many different uses
- Can be used with Paladin heating cable systems
- Can be used with Heat-Line cut-to-length heating cables
- Membrane available for metal roofs
- Thermostats and other control devices are optional
- Will not allow the heating cable to melt or overheat
- Energy efficient when compared with traditional roof de-icing systems
- Compatible with hydronic heated fluid melting systems
- Proven in extreme cold climates
- Fast installation with approved fasteners and/or appropriate adhesives



Specifications

- 4 feet of Aluminum EDGE-CUTTER flashing with cap
- 5 ½ inch width to be installed under roofing material
- Exposed cap width ¾ inch, can be painted to match roof covering
- Suitable for used with all Heat-Line self-regulating heating cables approved for roof
- Manufactured in North America
- 6 mil urethane membrane factory installed available upon request for steel roof applications

Applications

- Suitable for asphalt shingles, aluminum, steel, and even slate
- Residential roof applications
- Farms, agriculture
- Commercial, industrial
- Camps
- Mining



Aesthetically Pleasing De-Icing

EDGE-CUTTER feathered aluminum channel flashings are an aesthetically pleasing option to prevent ice build-up, icicles, or ice dams in roofing applications. When used in combination with Heat-Line, Paladin for Roof heating cable systems offers the most reliable, energy efficient roof de-icing system on the market.

Combine with Cut-to-Length Heat Cable

For commercial and or industrial applications, Heat-Line's Cut-to-Length heating cables offer an energy efficient and reliable solution when combined with Edge-Cutter. Each EDGE-CUTTER feathered aluminum channel flashing is 4 feet in length and has a channel to accommodate the self-regulating heating cable. The flashing is installed under the leading roof edge using screws, nails, or adhesives. The flashing will extend under the leading edge of roofing approximately 5 ½ inches.

Simple Installation

Multiple lengths of the EDGE-CUTTER can be butted together, with room for expansion, to reach required linear length of protection. The Paladin system or Heat-Line Cut-to-Length self-regulating heating cable is then installed within the channel and a cap secures it in place. As the heating cable warms, energy is transferred through the feathered aluminum to melt the leading edge of ice or snow.

Angled or Flat Edge

The EDGE-CUTTER system is provided in two separate models. The angled EDGE-CUTTER model is commonly used for the leading edge of the roof as it provides a proper drip edge, while the flat EDGE-CUTTER model is designed to be used in many other areas of the roof including but not limited to edges and valleys.

Low-Pitched, Valley, Edge

The versatility of the EDGE-CUTTER product makes it a perfect solution for low-pitched roofs, valleys, roof edges, and drip edges.

Versatile Applications

EDGE-CUTTER is designed to suit a wide variety of applications and work in conjunction with a diverse number of roofing materials including but not limited to asphalt shingles, aluminum, steel and even slate. If a metal roof is present, the EDGE-CUTTER channel flashing should be ordered with a 6 mm urethane membrane factory installed directly onto the flashing to prevent galvanic oxidation between dissimilar metals.

Tailor on Site

Although the EDGE-CUTTER flashings are provided in 4 inch lengths they can easily be tailored on site to suit your specific application.

EDGE-CUTTER | Product Code Guide

Example: **PLD- EC- B**

Product EDGE-CUTTER	Model	
	EC	4 foot angled / with cap / no membrane
	EC-B	4 foot angled / with cap / no membrane / x10
	EC-M	4 foot angled / with cap / with membrane
	EC-MB	4 foot angled / with cap / with membrane / x10
	ECF	4 foot flat / with cap / no membrane
	ECF-B	4 foot flat / with cap / no membrane / x10
	ECF-M	4 foot flat / with cap / with membrane
	ECF-MB	4 foot flat / with cap / with membrane / x10

NOTE: The EDGE-CUTTER system does not include heating cables. Heating cables are required for operation and must be purchased separately. Only recommend to be used with self-regulating heating cable technology.

EDGE-CUTTER | Accessories

EC-CAP	4' aluminum EDGE-CUTTER cap (CAP ONLY)	GIT-1	Gutter ice sensor (requires controller, PD-PRO or GF-PRO)
PLDI	Paladin heating cable system to specific length	SNOW-OWL	Aerial snow sensor (requires controller, PD-PRO or GF-PRO)
CUT-TO-LENGTH	Cut-to-Length heating cable	LCD-8	Configurable snow switch controller
DS-8C-CONTROLLER	Rain/snow sensor controller c/wremote 10' sensor	PD-PRO	Snow/ice controller
DS-8C-EX-50	Rain/snow sensor extension 50' kit for DS-8C	GF-PRO	Snow/ice controller with GFEP
		PLD-RDK	Downspout hanger kit

EDGE-CUTTER | Sample Application

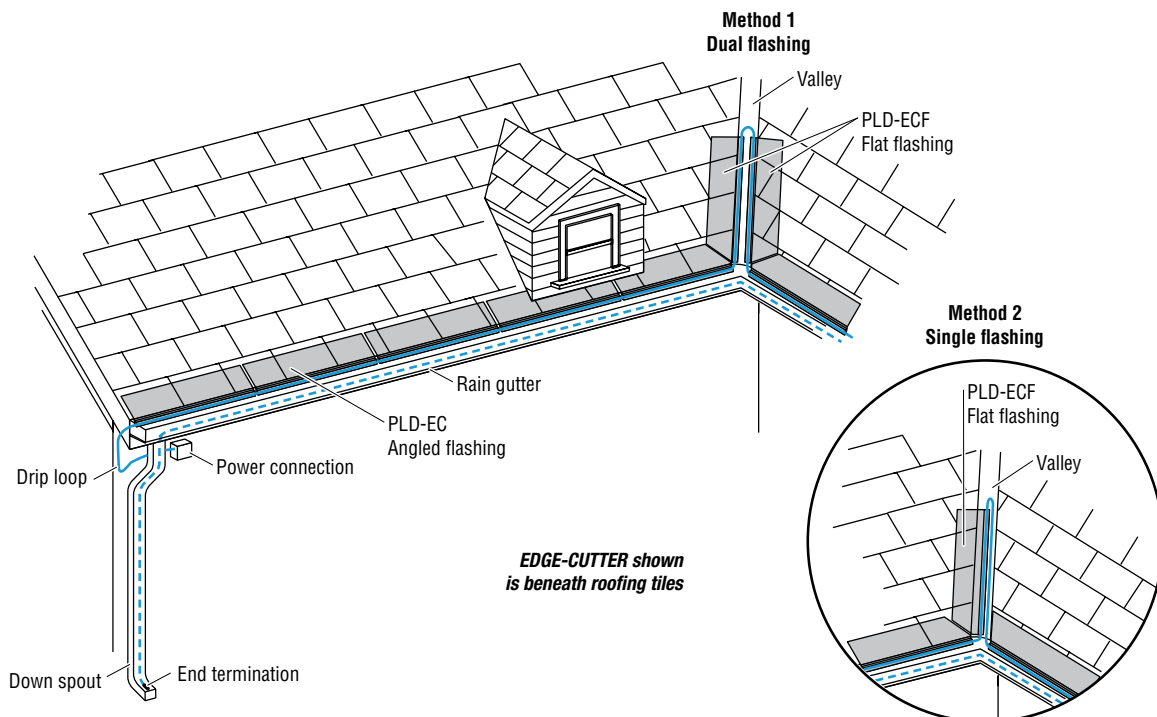

ArcticVent®



The World's Only Freeze Protected Plumbing Vent Stack.

ArcticVent is a certified commercial and residential freeze protected plumbing vent, proven throughout the circumpolar regions of the world and replaces many diameters and sizes of unprotected vents.



See more product information, videos, photos, technical documents, and more

Patents USA and Canada 

ArcticVent

Features & Benefits

- The only freeze protected plumbing vent stack available
- Available in hydronic or plug-in GFCI model or hard wire cord-set model depending on application
- Provides reliable plumbing vent freeze protection
- Suitable for all types of roofs (roof flashing not included)
- Up to 6 units per 15 amp dedicated 120 volt circuit
- No need to oversize stack diameters
- Can be adapted to existing PVC, ABS or other vent pipes
- Can be installed on many vent diameters with the use of a transition coupler
- Constructed out of LEXAN® for high strength in severe cold
- Longitudinal tether to prevent falling ice within stack
- Control devices such as timers and thermostats optional
- Proven results throughout circumpolar regions

Specifications

- cCSAus approved (Canada and USA) LR85446
- Enclosure Type 3R
- Available in electric and hydronic models
- 3-inch slip-fit coupling (2 part transition epoxy included)
- 3-inch (internal diameter) freeze protected LEXAN® enclosure
- 5-inch outside diameter
- Self-regulating/conductive polymer heating cable
- 120 volt or 240 volt, total 75 watts at 50° F
- Available with either GFCI plug or CS hard wire connection
- Standard warranty of 5 yrs with optional 10 yrs

Applications

- New and retrofit installation
- Residential
- Cabins, cottages
- Construction trailers
- Commercial, residential and industrial buildings
- Cold weather construction camps





cCSAus Approved

ArcticVent is the only cCSAus approved solution to freeze protect plumbing vent stacks and provide healthier living conditions in extremely cold climates.

Prolonged cold temperatures cause plumbing vent stacks to ice up and form a blockage as humid air rises, condenses and freezes. The result is pungent, unhealthy air backing up inside the dwelling which can be dangerous to the inhabitants.

Easily Installed

ArcticVent can be easily installed in new applications as the vent interfaces to standard pipes with the use of two part epoxy (included). ArcticVent can also be retro-fitted to existing 3 inch ABS or PVC pipe or adapted to fit other vent diameters. With ArcticVent, there is no longer a need to install unheated oversized diameter plumbing vents.

Continuous or on Demand

ArcticVent is constructed with LEXAN® for high strength in severe cold. While it is recommended to operate ArcticVent under continuous power in the colder months for freeze maintenance, it can be powered when required to thaw a frozen plumbing stack. The ArcticVent is constructed with a center longitudinal tether to ensure any ice formations within the vent stack melt fully and do not dislodge prior.

Hydronic or Electric

ArcticVent is available in both hydronic and electric models depending on application requirements. Electric models employ the unique and advanced performance of self-regulating heating cable technology which can effectively increase heat and energy output to sections along its length which are cold and simultaneously reduce heat and energy output to sections which are warm. Available in 120 volt or 240 volt, 75 watts total at 50° F.

Specifications

Each ArcticVent measures 3 feet long with a 3 inch ID and 5 inch OD.

Electric models available in 120 volt or 240 volt, GFCI or CS versions.

Hydronic models come with brass male thread for connection interface.

Proven

ArcticVent is proven effective in the most severe cold climates. Hundreds of units are installed in the most northern communities in Canada without fail for years. ArcticVent is constructed with LEXAN® for high strength in severe cold. While it is recommended to operate ArcticVent under continuous power in the colder months for freeze maintenance, it can be powered when required to thaw a frozen plumbing stack.

Energy Efficiency

To further increase the energy efficiency of your ArcticVent unit, control devices can be added to the system. The ArcticVent unit is already internally insulated to reduce heat loss and increase energy efficiency. The addition of a thermostat would allow you to duty cycle your ArcticVent system based on ambient air temperature, while a timer would duty cycle the ArcticVent on and off based on desired preset.

ArcticVent | Product Code Guide

Electric ArcticVent

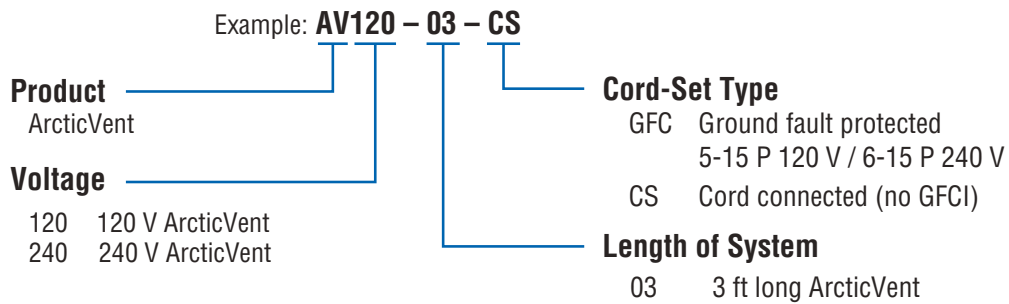

NOTE: Nominal power output of ArcticVent system is 75 W/ft @ 50°F (10°C).

Hydronic ArcticVent

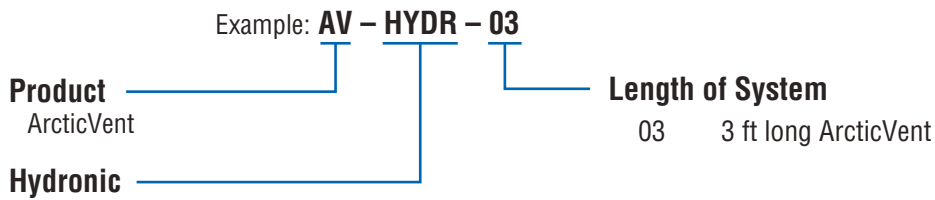

ArcticVent | Accessories

TIMER-120P 120V plug-in timer (GFC)

TIMER-240P 240V plug-in timer (GFC)

TIMER-CS 120/240V hard wire timer (CS)

MA-10 120/240V GFCI/ELCI (CS)

AV-AS-FLASH ArcticVent roof flashing for asphalt

AV-ST-FLASH ArcticVent roof flashing for steel

WARRANTY Extended 10 year limited warranty

ArcticVent | Sample Application

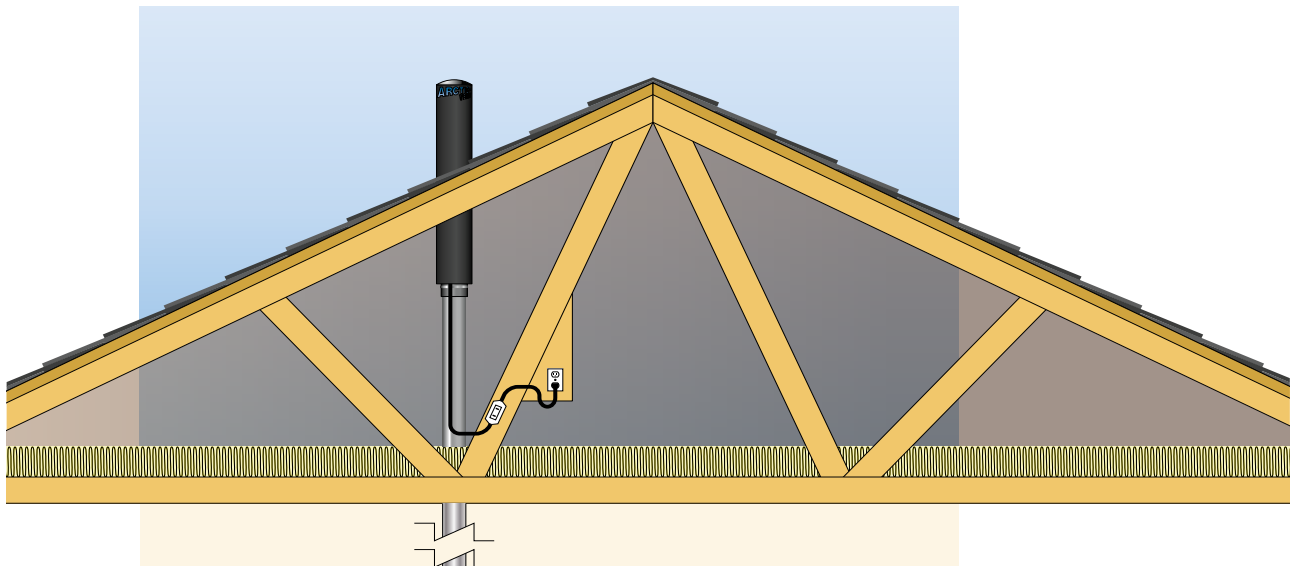

ArcticVent®-HT



*The World's Only Passive Engineered Solution
Designed to Freeze-Protect the Exposed Length
of a Plumbing Vent Stack*

ArcticVent-HT is an innovative, self-contained unit that prevents ice build-up while requiring no power, produces zero carbon footprint and easily installs inside existing plumbing vent stacks in minutes.



SCAN ME

See more product information, videos, photos, technical documents, and more

Patents Pending USA and Canada

ArcticVent-HT

Features & Benefits

- Requires no electricity or other power source, zero carbon operating footprint
- Quickly and easily installed in a matter of minutes
- The only passive engineered solution incorporating advanced vapour chamber technology available on the market
- No need to oversize stack diameters
- Constructed out of hard black anodized aluminum for high strength in severe cold and resistance to corrosion
- Engineered for enhanced heat transfer
- Proven results throughout circumpolar regions
- 5 year limited warranty

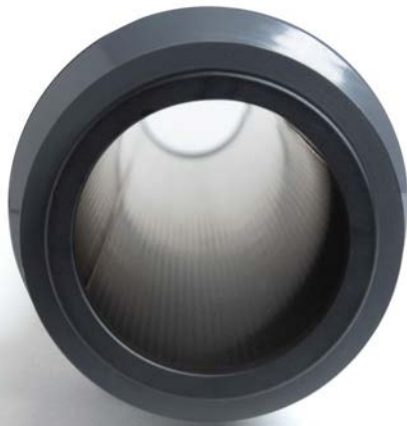

Specifications

- Non-electric, non-hydronic plumbing vent freeze protection system
- Hard black anodized aluminum casing for resistance to corrosion
- Proprietary vapour chamber technology provides efficient movement of energy
- Designed for working ambient temperatures ranging from -58F (-50C) to 194F (90C)
- Suitable for all types of roofs
- Suitable for 3 inch ABS and PVC vent only
- Adapters may be available for other pipe types and sizes
- Always default to the ATV-30-42-01 model as long as your existing plumbing vent layout can accommodate the length

Applications

- Residential buildings
- Commercial/Industrial buildings
- Modular homes and northern research laboratories
- Temporary mining and exploration camps
- Construction trailers





No Power Source Required

The unique advantage of ArcticVent-HT is its cutting-edge vapour chamber technology. ArcticVent-HT incorporates a proprietary technology to transfer existing warmth from within the building to the upper exposure opening. This advanced heat tube technology operates without the need for any power source and is proven to perform, even in the most extreme cold climates of North America.

Easily Installed

ArcticVent-HT can be used in new installations or retrofit into existing vent stacks where a freeze protected plumbing vent stack is required. The ArcticVent-HT is designed to slide into existing 3-inch plumbing ABS and PVC vent stacks without their removal. No adhesives or solvents are required. The connection is intentionally designed to be detachable, allowing the ArcticVent-HT to remain serviceable.

Robust Materials

ArcticVent-HT is fabricated from durable black anodized aluminum, offering exceptional strength even in the most frigid conditions and delivering outstanding corrosion resistance.

Specifications

ArcticVent-HT is available in 2 lengths, a 42" model and a 24" model. It is recommended to default to the 42" model of the ArcticVent-HT for optimal performance, as long as your existing plumbing vent layout can accommodate the length. ArcticVent-HT is designed to interface directly with a 3" ABS and PVC vent only. Adaptors may be available for other pipe types and sizes.

Proven

ArcticVent-HT is tested and proven effective in the most severe cold climates. ArcticVent-HT shares many of the same advanced characteristics of the original electric-powered ArcticVent which has demonstrated ease of installation and reliability for over 20 years.

ArcticVent-HT | Product Code Guide

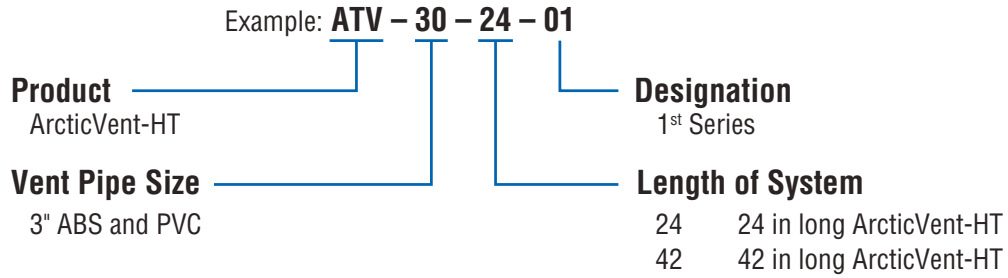

ArcticVent-HT | Accessories

- INSUL-3.00** Insulation sleeve for 3 inch ID pipe (3 ½ inch ID, 6 ft long)
- INSUL-PAD** Elastometric flexible insulation (10 ft long, 6 inch wide, ½ inch thick)

ArcticVent-HT | Sample Application

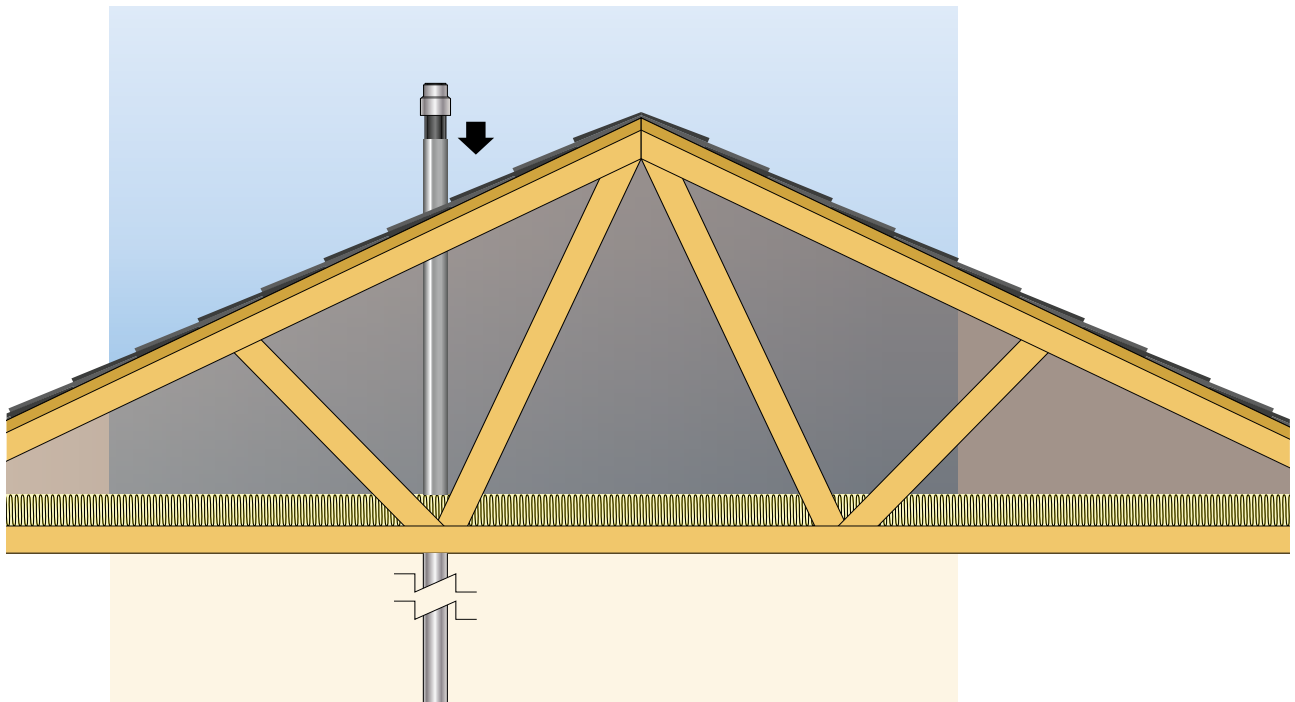

Cut-to-Length Heating Cable

Industrial and Commercial Self-Regulating Heating Cable.

Cut-to-Length Heating Cables are top quality commercial, industrial self-regulating heating cables and power connection kits for ordinary and hazardous locations, roof and gutter de-icing.



See more product information, photos, technical documents, and more



General Heater Specifications

Buss Wire	14-16 AWG copper or nickeled copper
Conductive core	Self-regulating/conductive polymer
Inner jacket	Polyolefin
Metallic overshield/Braid	Copper, tinned copper or stainless steel
Outer jacket	Modified Polyolefin or Fluoropolymer
Watts per foot/meter	3, 5, 8, 10/foot or 10-33/meter
Voltage	110 - 120 Vac or 208 - 277 Vac
Approvals	CSA, FM, UL
Environmental use(s)	<ul style="list-style-type: none"> • Ordinary areas • Div. 2 hazardous locations • Corrosive environments • Roof and gutter
Reel length	Up to 1000 feet
Water resistant jacket	Yes
Flame retardant jacket	Yes
Can be overlapped	Yes
Applications	<ul style="list-style-type: none"> • Freeze protection of pipes • Fire protection system piping • Chilled water and plumbing pipes • Sump pump discharge pipes • Exposed P-traps • Cooling towers • Vessel freeze protection • Fluid flow and viscosity maintenance • Process temperature maintenance • Roof and gutter

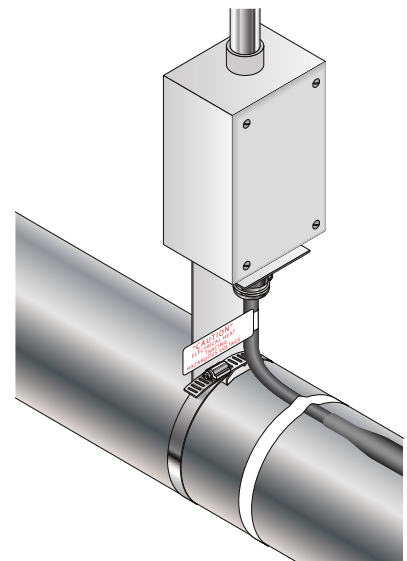
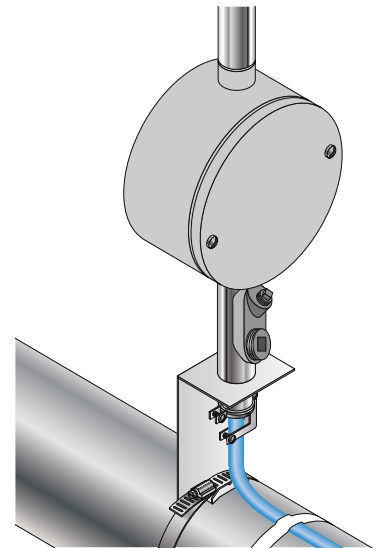

Self-Regulating Heating Cable

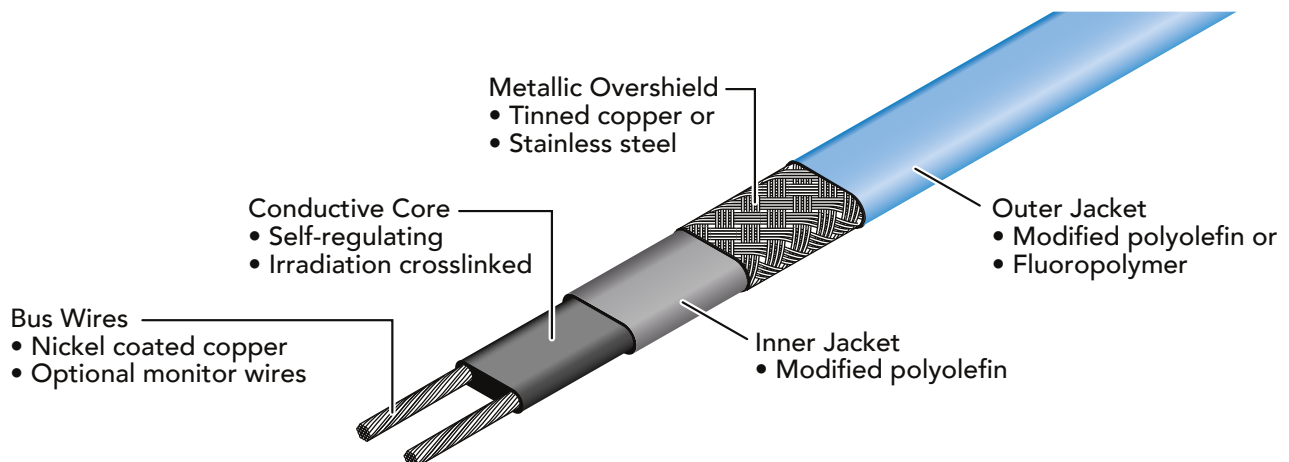



Heating Cable Options

Heat-Line provides excellent Cut-to-Length heat cables in a large or small order requirements at very competitive prices. These cables can maintain temperatures up to 150°F (65°C) and survive intermittent exposure up to 185°F (85°C) with power applied. They are designed for all types of heat tracing including pipe tracing, roof and gutter de-icing, vessel tracing and many more. All heating cables are North American made by the top manufacturers providing you a reliable solution.

Cost Savings

Many manufacturers specify their specific cables in various building plans, and Heat-Line's vast resource of products will almost always meet the building specification, providing equivalent performance with huge cost savings to the contractor. Heat-Line provides excellent Cut-to-Length heating cables in large or small order requirements at very competitive prices.

Industrial, Commercial

Heat-Line is a sole source, high volume provider of multiple types of industrial and commercial self-regulating heating cables, components and controls. Heat-Line carries major inventories with a full understanding of the products and can provide extremely competitive pricing.

Meets or Exceeds Most Building Specs

Heating cables are available in 120, 208, 240 and 277 volts, and wattages ranging from 3 to 10 watts per foot or 10 to 33 watts per meter. All heating cables meet or exceed most building specifications and carry regulatory approvals from CSA, FM and/or UL for ordinary and hazardous locations. Control options include: ambient and line sensing thermostats, snow melt sensors, ground fault protected thermostats and more.

Common Applications

Heat-Line Cut-to-Length freeze protection heating cables are ideal for keeping metallic and non-metallic pipes from freezing. These heat cables provide safe, reliable heat tracing for freeze protection of pipes, valves, tanks and similar applications. In commercial construction applications, these heaters can be used on a variety of applications such as; cooling towers, chilled water and plumbing pipes, sump discharge pipes, fire protection system piping and exposed P-traps. For industrial applications, their usage can include; water treatment facilities, vessel freeze protection and safety lines. Cut-to-Length heating cables are also ideal for process temperature maintenance, pipe freeze protection, fluid flow and viscosity maintenance. Medium and high temperature industrial and commercial grade self-regulating heating cables are also available.

Self-Regulating Technology

All Heat-Line Cut-to-Length heating cables offer the unique and advanced performance of self-regulating heating cable technology. These heaters can effectively increase heat and energy output to sections along its length which are cold and simultaneously reduce heat and energy output to sections which are warm. Even in applications where pipes are intended to be dry for short or extended periods of time, the heating cable will never over-heat or melt the pipe. These high quality heaters give you the peace of mind of reliable freeze protection without the risk. It has become an essential product for electricians, engineers and building officials overseeing commercial, industrial and municipal projects to provide safe and reliable pipe freeze protection.

Cut-to-Length Heating Cable Ordering Chart

2700 Series Heating Cable Example Shown

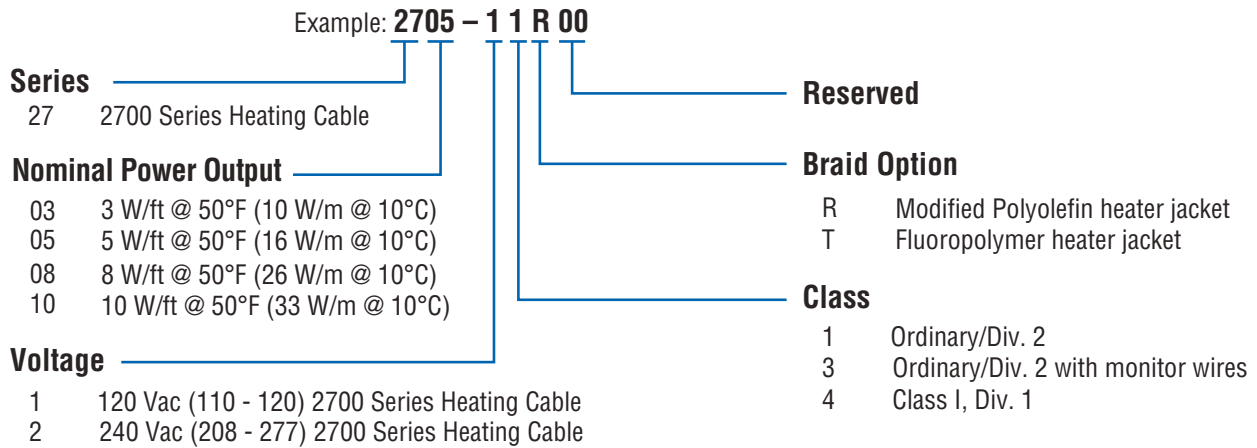

Electrical Connection Kits | Product Codes

- 1548-40000** Power and end seal connection kit, FM hazardous and non-hazardous
- 1548-4000C** Power and end seal connection kit, CSA non-hazardous
- 1548-4010C** Power and end seal connection kit, CSA hazardous and non-hazardous
- 1548-40PTJ** Power connection kit, FM hazardous and non-hazardous
- 1548-40RGP** Power and end seal kit, roof and gutter, CSA, UL
- SRHC-ES** End seal kit, CSA/FM hazardous and non-hazardous

For specific approval information on the above connection kits contact Heat-Line

Note: Other heating cables and electrical connection kits available by special request.

Cut-to-Length Heating Cable | Accessories

GFA-STAT	120/240V hard wire thermostat GFEP (CS)	GIT-1	Gutter ice sensor (requires controller, PD-PRO or GF-PRO)
1660-13A11	Line sensing thermostat, 25-325F, NEMA 4X Ordinary	SNOW-OWL	Aerial snow sensor (requires controller, PD-PRO or GF-PRO)
1660-13A12	Line sensing thermostat, 25-325F, FM Class 1 Div 1	LCD-8	Configurable snow switch controller
1660-18911	Ambient sensing thermostat, Ordinary Location	PD-PRO	Snow/ice controller
MA-10	120/240V GFCI/ELCI (CS)	GF-PRO	Snow/ice controller with GFEP
DS-8C-CONTROLLER	Rain/snow sensor controller c/w remote 10' sensor	PLD-RDK	Downspout hanger kit
DS-8C-EX-50	Rain/snow sensorextension 50' kit for DS-8C	PLD-RC	Roof clips (package of 10)
		1528-01017	2700 Series fiberglass tape, 130C rated, 60 yards or 180ft per roll ½" wide
		PLD-EC	EDGE-CUTTER to suit (refer to page 51)

Thermostats & Timers

Complete Range of Control Devices to Increase Heating Cable Efficiency.

Thermostats and or timers are a beneficial optional accessory when incorporated with any Heat-Line freeze protection system. Regardless of the overall system length and or operating voltage, a Heat-Line thermostat or timer will reduce energy costs by decreasing overall energy consumption.

A thermostat can be added to Heat-Line systems in order to duty cycle the heating cable at a specified temperature, where as a timer can be added to duty cycle the heating cable at specific timed intervals.



See more product information, videos, photos, technical documents, and more



Thermostats/Timers



HLJ-STAT

- cULus listed
- Easy to read front panel liquid crystal display
- 3 year original manufacturers limited warranty
- Electronic, plugs into standard 5-15R 120 volt 15 amp outlet
- 6m (19.6ft.) temperature sensor lead
- Comes with DIN rail for easy mounting
- Pre-programmed factory settings; ON 8.3°C (47°F)/OFF 11°C (52°F)
- 1.8m (6 ft) electrical cord with combined plug and outlet
- Adjustable set-point; minimum -34°C (-30 °F)/maximum 100°C (212°F)



HLA-120

- ETL c-us approved
- Easy to read front panel display
- 1 year limited warranty
- Electronic, plugs into standard 5-15R 120 volt 15 amp outlet
- 6.7m (22ft.) temperature sensor lead
- Programmable, 5/2 day programming (Weekdays and weekends can be different)
- Adjustable set-point, minimum temperature setting 7°C (45°F)



GFA-STAT

- cULus listed and certified
- 2 year original manufacturers limited warranty
- Nonhazardous locations NEMA 4X enclosure
- Supply voltage 120, 208, 240, 277 volts, single phase
- Maximum ampacity 30 amps at 277 VAC
- Sensor lead length of 20 feet (6m)
- Hard-wired usage only (Professional tradesperson install recommended)
- Adjustable temperature set points of 30°F, 38°F, 45°F and/or 50°F (-1.1°C, 3.3°C, 7.2°C and or 10°C)
- GFCI integral to unit, 30 mA protection



KHL-STAT-2

- Water and dust resistance to IP67
- RoHS compliant
- 5 year original manufacturers limited warranty
- Supply voltages 6 to 28 volts DC
- Load control up To 30 amps
- Accurate set-points, On at 45°F (7°C) and Off at 50°F (10°C)



HL-TIMER-CS/120P/240P

- cCSAus certified and listed under energy management equipment
- Supply voltage 120 or 240 volts, single phase, 60 Hz
- Resistive rating: 20 amps at 120/240VAC, 28 VDC
- Enclosure type 3
- CS model timer designed for hard usage installation with Heat-Line CS model heating cable systems
- 120P model timer for 120 volt applications only, provided with Female 5-15R and Male 5-15P plug end tails for use with Heat-Line GFC 120 volt model heating cable systems
- 240P model timer for 240 volt applications only provided with Female 6-15R and Male 6-15P plug end tails for use with Heat-Line GFC 240 volt model heating cable systems
- Provides 8 field selectable cycles durations (30sec., 1min., 3mins., 5mins., 10mins., 30mins., 1hr. and 4hrs.)
- Provides 30 different precise percentage selection options for ON TIME

Note: Other thermostat and control options not listed above are available from Heat-Line. Please contact Heat-Line directly to discuss other thermostat options and control devices not listed.

Insulation

Complete range of pipe insulation types and sizes.

Heat-Line systems are self-regulating, allowing insulation to be added without the concern of the pipe overheating. A thermally insulated pipe requires much less heat to protect and is not as susceptible to freezing. Extreme or variable temperature changes are not a concern as the pipe insulation provides better thermal consistency and efficiency throughout the entire pipe length.

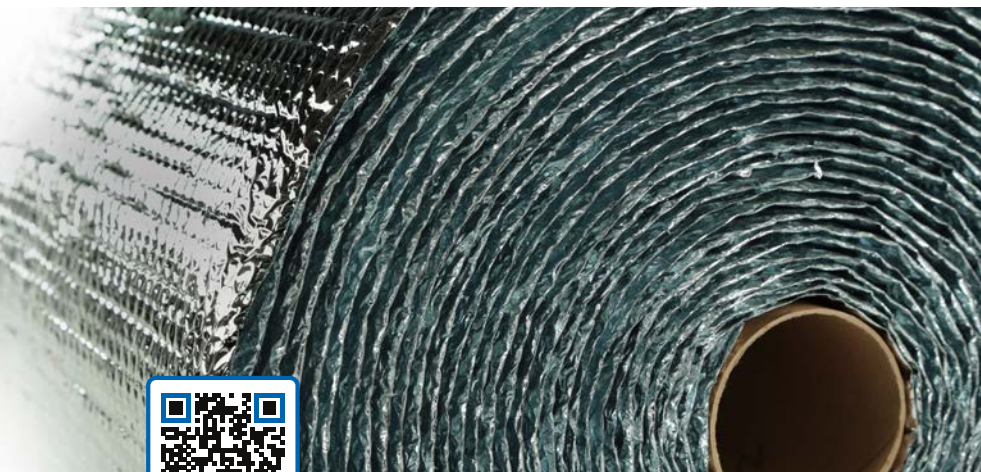

See more product information, videos, photos, technical documents, and more

Insulation

Minimize Heat Loss

While self-regulating technology is very efficient, it is important to understand there is always great heat loss from an uninsulated pipe, which causes the heating cable to produce high heat to compensate. When insulation is applied, heat is retained (heat loss minimized) within the pipe, allowing the heating cable to produce less heat to maintain the same temperature. For example, it would be foolish to install the most energy efficient furnace in your home and then fail to insulate your walls and ceilings. The furnace will only operate to its highest standard when used with insulation and a thermostat. The same idea applies with Heat-Line systems.

Do You Require Insulation?

Any section of Heat-Line freeze protected pipe remaining above ground is required to be thermally insulated. In all new applications insulation is recommended for energy efficiency. Note: For lake or river applications, insulation is only required to the water's edge (at low water mark). Water-proof, styrofoam foam board type insulation can also be purchased from local building centers and is an excellent choice for direct earth burial applications.

Insulation | Product Codes

INSUL-1.00x6	Closed cell polyethylene insulation sleeve for 1" ID water pipes. Insulation is 1 5/8" ID, 3/4" wall, 6' in length
INSUL-1.25x6	Closed cell polyethylene insulation sleeve for 1 1/4" ID water pipes. Insulation is 1 7/8" ID, 3/4" wall, 6' in length
INSUL-2.00x6	Closed cell polyethylene insulation sleeve for 2" ID water pipes. Insulation is 2 5/8" ID, 3/4" wall, 6' in length
INSUL-3.00x6	Closed cell polyethylene insulation sleeve for 3" ID water pipe. Insulation is 3 1/2" ID, 3/4" wall, 6' in length
INSUL-4.00x6	Closed cell polyethylene insulation sleeve for 3" ID water pipe. Insulation is 4 1/2" ID, 1" wall, 6' in length
INSUL-PAD	Elastomeric flexible closed cell insulation, 1/2" (12.5mm) thick, 6" (152mm) Wide, 10' (3m) long
INSUL-FOIL	16" wide aluminum reflective metalized foil bubble insulation, available by the foot or by each 125 ft (38m) roll

Insulation | Accessories

HLP-TAPE	Tape for insulation sleeve butt joints (100ft)
FOIL-TAPE	All weather aluminum foil tape (150ft)
INSUL-WRAP-1.00-025	Black ballistic polyester insulation covering designed to fit INSUL-1.00"X0.75"X6' SELF SEAL, 25' per roll
INSUL-WRAP-1.00-150	Black ballistic polyester insulation covering designed to fit INSUL-1.00"X0.75"X6' SELF SEAL, 150' per roll
INSUL-WRAP-1.25-025	Black ballistic polyester insulation covering designed to fit INSUL-1.25"X0.75"X6' SELF SEAL, 25' per roll
INSUL-WRAP-1.25-150	Black ballistic polyester insulation covering designed to fit INSUL-1.25"X0.75"X6' SELF SEAL, 150' per roll
INSUL-WRAP-2.00-025	Black ballistic polyester insulation covering designed to fit INSUL-2.00"X0.75"X6' SELF SEAL, 25' per roll
INSUL-WRAP-2.00-150	Black ballistic polyester insulation covering designed to fit INSUL-2.00"X0.75"X6' SELF SEAL, 150' per roll

Philmac[®] Fittings

Specialized Plumbing Compression Fittings.

Heat-Line is pleased to offer a wide range of Philmac 3G Compression style fittings designed for connection of polyethylene water pipes which includes SIDR IPS, OD IPS, and CTS normal dimension pipes. Philmac fittings are both NSF and CSA certified for potable water applications, both in above and below ground applications.



See more product information, photos, technical documents, and more



Philmac Fittings

Proudly Recommended

Heat-Line is proud to recommend Philmac 3G Compression fittings as the premium choice for customers concerned with a long term performance and reliability. Heat-Line offers an extensive line-up of Philmac 3G plumbing fittings to meet the growing needs of the plumbing industry. The Heat-Line Product Codes below represent the most commonly requested Philmac fittings, and therefore are readily available in inventory.

Special Orders Available

Heat-Line's extensive inventory of Philmac 3G fittings includes many other fittings of various sizes and pipe applications not listed below. Heat-Line can also special order to provide Philmac Fittings for applications beyond the current inventory.

Design

The Philmac 3G Compression series of fittings provide a compact, lightweight, and user friendly design that reduces the overall possibility of pipe twist while reaming completely serviceable.

Market Leaders

Philmac 3G Compression fittings are design to exceed required life expectancy ratings of 50 years.

Philmac 3G SIDR Compression Fittings | Product Codes

PC-100	Coupling for 1 inch ID compression
PC-125	Coupling for 1 ¼ inch ID compression
PMA-100	Male adapter, 1 inch ID compression x 1 inch MIP thread
PMA-100/125	Male adapter, 1 inch ID compression x 1¼ inch MIP thread
PMA-125	Male adapter, 1¼ inch ID compression x 1¼ inch MIP thread
PMA-125/100	Female adapter, 1¼ inch ID compression x 1 inch FIP thread
PFA-100	Female adapter, 1 inch ID compression x 1 inch FIP thread
PFA-125	Female adapter, 1¼ inch ID compression x 1 ¼ inch FIP thread
PBF-100	Female 90 degree elbow adapter, 1 inch ID compression x 1 inch FIP thread
PBF-125	Female 90 degree elbow adapter, 1¼ inch ID compression x 1¼ inch FIP thread

Philmac 3G CTS Compression Fittings | Product Codes

PC-100CTS	Coupling for 1 inch CTS compression
PC-125CTS	Coupling for 1 ¼ inch CTS compression
PMA-100CTS	Male adapter, 1 inch CTS compression x 1 inch MIP thread
PFA-100CTS	Female adapter, 1 inch CTS Compression x 1 inch FIP thread

Submersible Pump Stand and Submersible Pump Wire

Lake line water supply accessories.

Winterizing a water supply pipe from a lake, river, and or other water body is one of the most rewarding investments a homeowner can make in their property. Heat-Line makes this investment possible by developing and manufacturing the most advanced heating cable systems available, and offers submersible pump wire and submersible pump stands to compliment your water supply system.



Pump Stand



SCAN ME

Pump Wire



SCAN ME

See more product information, photos, technical documents, and more



Submersible Pump Stand and Submersible Pump Wire

Submersible Pump Stand

Heat-Line offers a submersible pump stand kit which provides vertical steadiness, stabilization, and mechanical protection for your pump, without jeopardizing performance. It is designed to suit many types of submersible pumps and may be adjusted in the field to suit various conditions or requirements. Heat-Line can also provide custom submersible pump stands to suit larger pumps at the request of our customers.

Submersible Pump Wire

Heat-Line recommends and supplies high quality TECK-90 armoured jacketed cables with watertight breakout boots for electrical pump installations in lakes, rivers and other open water bodies. This cable is sealed from moisture ingress to reduce insulation resistance breakdown (IR drop). These cables can be buried directly in the ground, are durable and offer excellent mechanical protection all the way to the pump.

The advantage to the TECK-90 armour jacketed submersible pump wire is that unlike common unprotected PVC jacketed deep well pump wire, the armoured wire prevents mechanical damage within the waterbody and over or under the ground. Furthermore, the wet-location approved TECK-90 cable prevents moisture from breaking down the internal conductor insulation which can lead to IR drop and GFCI conditions.

Submersible Pump Stand | Product Code

PUMP-STAND Submersible Pump Stand Kit

Submersible Pump Wire | Product Codes

T90-123	TECK90, 3 Wire with Ground, 12 AWG, Armoured Jacketed Cable with Watertight Breakout Boot and TECK Connector
T90-122	TECK90, 2 Wire with Ground, 12 AWG, Armoured Jacketed Cable with Watertight Breakout Boot and TECK Connector
T90-103	TECK90, 3 Wire with Ground, 10 AWG, Armoured Jacketed Cable with Watertight Breakout Boot and TECK Connector
T90-102	TECK90, 2 Wire with Ground, 10 AWG, Armoured Jacketed Cable with Watertight Breakout Boot and TECK Connector
T90-083	TECK90, 3 Wire with Ground, 8 AWG, Armoured Jacketed Cable with Watertight Breakout Boot and TECK Connector

Sample Application

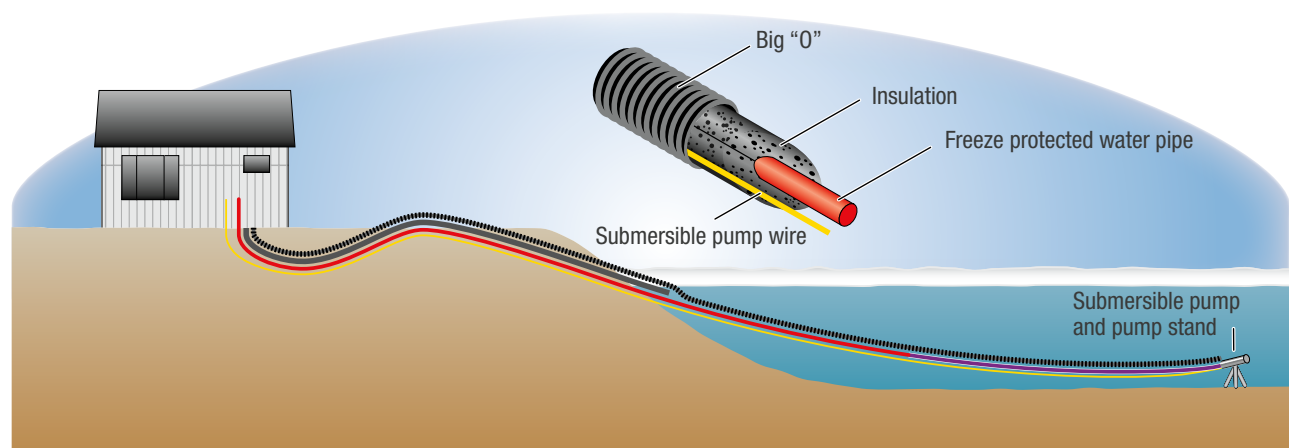

MilliAMP

A Certified, Stand-Alone 10 MilliAMP GFCI/ELCI Equipment Protection Device.

MilliAMP is an Equipment Leakage Circuit Interrupter (ELCI) designed for electrical equipment and shock protection of sewage pumps, water pumps, heating cables and many other electrical appliances.



SCAN ME

See more product information, videos, photos, technical documents, and more



MilliAMP

Development

MilliAMP was developed by Heat-Line to supply ground fault protection which is not specific to any particular electrical panels or equipment.

Specifications

The MilliAMP MA-10 is a equipment protection device engineered to provide standalone 10mA GFCI/ELCI equipment protection. Compatible with both 120 volt 20 amp and 240 volt 16 amp circuits. Applications include water supply pumps and heating cable devices.

CAUTION

A MilliAMP device is primarily designed for equipment protection and while it does provide a high level of safety, it is not a Class A Ground Fault Circuit Interrupter (GFCI).

MilliAMP | Product Codes

MA-10 ELCI with enclosure, CSA approved, 10 mA typical trip level, 120 volt, 20 amp or 240 volt, 16 amp voltage rating

Sample Application

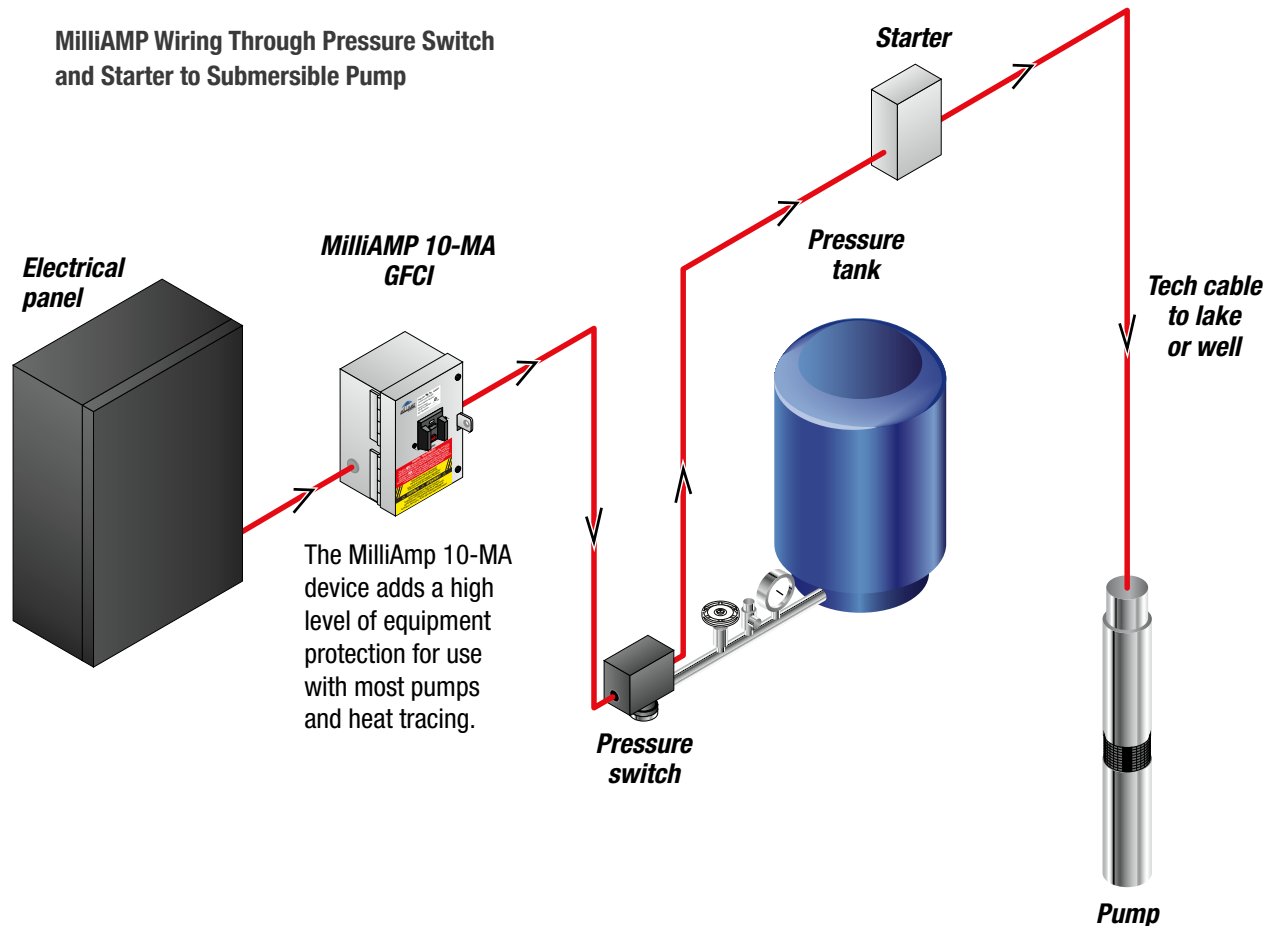

The Most Advanced Freeze Protection Systems in the World

The Heat-Line Difference:

Heat-Line brand products are specifically manufactured to solve issues encountered in extreme cold climates. Industry-leading knowledge and experience, respect for our customers, and attention to detail has generated a loyal following of customers that trust Heat-Line products, and that will never change. Part of respecting and developing a loyal customer base is developing solutions that take into account the concerns and needs of those customers. As a result Heat-Line provides products that are developed by experts within the field, supported by award winning customer service, offer efficient operation, manufactured of only the finest self-regulating heating cable and represent marketing leading quality control.





Head Office and Manufacturing Operations

Heat-Line
1095 Green Lake Road
Algonquin Highlands, Ontario
Canada, K0M 1S0
Tel: 1-705-754-4545
1-800-584-4944
Fax: 1-705-754-4567
info@heatline.com

Represented by:

Retro-Line, Retro-DWS, Retro-FM, CARAPACE, Heat-Line, Paladin, Kompensator, EDGE-CUTTER and ArcticVent are registered trademarks of Heat-Line Corporation. All other trademarks are the property of their respective owners. Many of these products are protected by numerous patents.

Heat-Line Freeze Protection Systems

1095 Green Lake Road
Algonquin Highlands, Ontario,
Canada, K0M 1S0
Tel: 1-705-754-4545
1-800-584-4944
Fax: 1-705-754-4567
info@heatline.com
www.heatline.com

IMPORTANT: All information in this catalogue, including illustrations, is believed to be reliable. Users, however, should independently evaluate the suitability of each product for their particular application. Heat-Line, a Division of Christopher MacLean Ltd., makes no warranties as to the accuracy or completeness of the information, and disclaims any liability regarding its use. Heat-Line's only obligations are those in the Heat-Line Standard Terms and Conditions of Sale for its products, and in no case will Heat-Line be liable for any incidental, indirect, or consequential damages arising from the sale, resale, use, or misuse of its products. Specifications are subject to change without notice. In addition, Heat-Line reserves the right to make changes—without notification to Buyer—to processing or materials that do not affect compliance with any applicable specification.

Heat-Line is a division of Christopher MacLean Ltd.