

ArcticVent®



The World's Only Freeze Protected Plumbing Vent Stack.

ArcticVent is a certified commercial and residential freeze protected plumbing vent, proven throughout the circumpolar regions of the world and replaces many diameters and sizes of unprotected vents.



See more product information, videos, photos, technical documents, and more

Patents USA and Canada 

ArcticVent

Features & Benefits

- The only freeze protected plumbing vent stack available
- Available in hydronic or plug-in GFCI model or hard wire cord-set model depending on application
- Provides reliable plumbing vent freeze protection
- Suitable for all types of roofs (roof flashing not included)
- Up to 6 units per 15 amp dedicated 120 volt circuit
- No need to oversize stack diameters
- Can be adapted to existing PVC, ABS or other vent pipes
- Can be installed on many vent diameters with the use of a transition coupler
- Constructed out of LEXAN® for high strength in severe cold
- Longitudinal tether to prevent falling ice within stack
- Control devices such as timers and thermostats optional
- Proven results throughout circumpolar regions

Specifications

- cCSAus approved (Canada and USA) LR85446
- Enclosure Type 3R
- Available in electric and hydronic models
- 3-inch slip-fit coupling (2 part transition epoxy included)
- 3-inch (internal diameter) freeze protected LEXAN® enclosure
- 5-inch outside diameter
- Self-regulating/conductive polymer heating cable
- 120 volt or 240 volt, total 75 watts at 50° F
- Available with either GFCI plug or CS hard wire connection
- Standard warranty of 5 yrs with optional 10 yrs

Applications

- New and retrofit installation
- Residential
- Cabins, cottages
- Construction trailers
- Commercial, residential and industrial buildings
- Cold weather construction camps





cCSAus Approved

ArcticVent is the only cCSAus approved solution to freeze protect plumbing vent stacks and provide healthier living conditions in extremely cold climates.

Prolonged cold temperatures cause plumbing vent stacks to ice up and form a blockage as humid air rises, condenses and freezes. The result is pungent, unhealthy air backing up inside the dwelling which can be dangerous to the inhabitants.

Easily Installed

ArcticVent can be easily installed in new applications as the vent interfaces to standard pipes with the use of two part epoxy (included). ArcticVent can also be retro-fitted to existing 3 inch ABS or PVC pipe or adapted to fit other vent diameters. With ArcticVent, there is no longer a need to install unheated oversized diameter plumbing vents.

Continuous or on Demand

ArcticVent is constructed with LEXAN® for high strength in severe cold. While it is recommended to operate ArcticVent under continuous power in the colder months for freeze maintenance, it can be powered when required to thaw a frozen plumbing stack. The ArcticVent is constructed with a center longitudinal tether to ensure any ice formations within the vent stack melt fully and do not dislodge prior.

Hydronic or Electric

ArcticVent is available in both hydronic and electric models depending on application requirements. Electric models employ the unique and advanced performance of self-regulating heating cable technology which can effectively increase heat and energy output to sections along its length which are cold and simultaneously reduce heat and energy output to sections which are warm. Available in 120 volt or 240 volt, 75 watts total at 50° F.

Specifications

Each ArcticVent measures 3 feet long with a 3 inch ID and 5 inch OD.

Electric models available in 120 volt or 240 volt, GFCI or CS versions.

Hydronic models come with brass male thread for connection interface.

Proven

ArcticVent is proven effective in the most severe cold climates. Hundreds of units are installed in the most northern communities in Canada without fail for years. ArcticVent is constructed with LEXAN® for high strength in severe cold. While it is recommended to operate ArcticVent under continuous power in the colder months for freeze maintenance, it can be powered when required to thaw a frozen plumbing stack.

Energy Efficiency

To further increase the energy efficiency of your ArcticVent unit, control devices can be added to the system. The ArcticVent unit is already internally insulated to reduce heat loss and increase energy efficiency. The addition of a thermostat would allow you to duty cycle your ArcticVent system based on ambient air temperature, while a timer would duty cycle the ArcticVent on and off based on desired preset.

ArcticVent | Product Code Guide

Electric ArcticVent

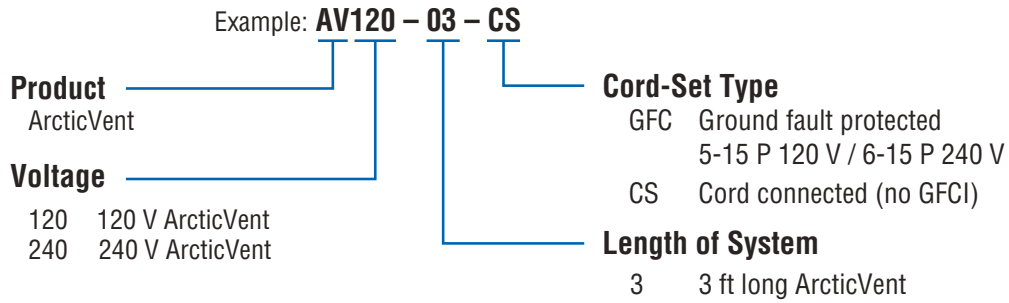

NOTE: Nominal power output of ArcticVent system is 75 W/ft @ 50°F (10°C).

Hydronic ArcticVent

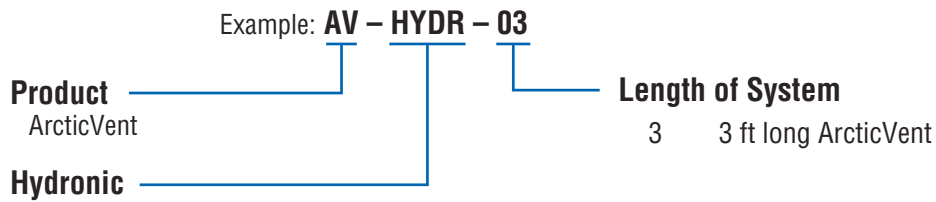

ArcticVent | Accessories

TIMER-120P 120V plug-in timer (GFC)

TIMER-240P 240V plug-in timer (GFC)

TIMER-CS 120/240V hard wire timer (CS)

MA-10 120/240V GFCI/ELCI (CS)

AV-AS-FLASH ArcticVent roof flashing for asphalt

AV-ST-FLASH ArcticVent roof flashing for steel

WARRANTY Extended 10 year limited warranty

ArcticVent | Sample Application

