

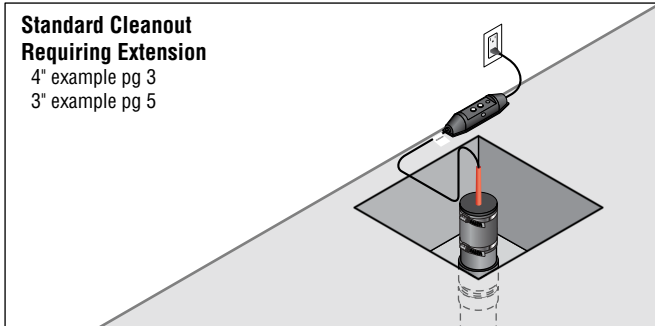

Retro-DWS® — Other Methods

Internal Heating Cable System for Sewer Pipe and Waste Drain Applications

Installation Instructions



Standard Cleanout Requiring Extension
4" example pg 3
3" example pg 5

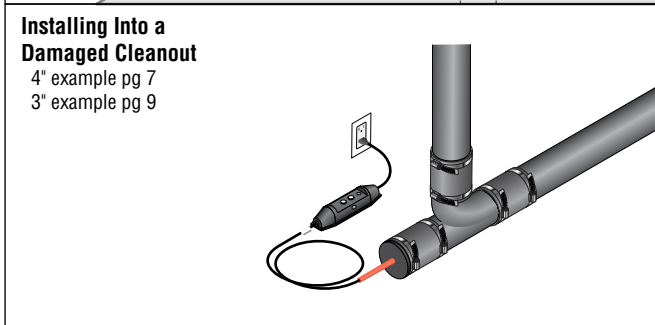

Installing Into a Damaged Cleanout
4" example pg 7
3" example pg 9

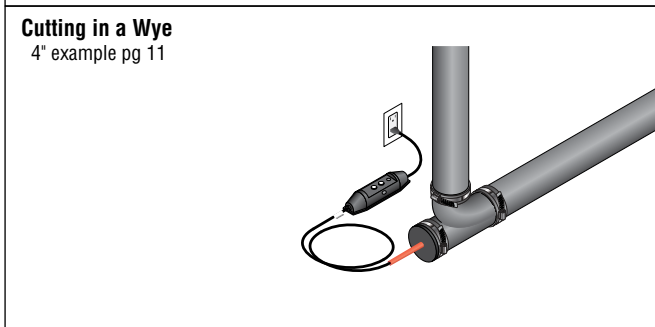

Cutting in a Wye
4" example pg 11

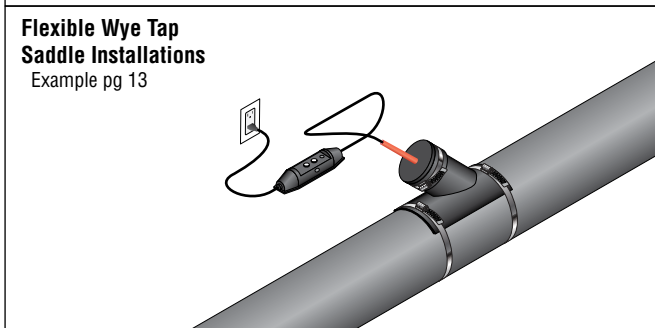

Flexible Wye Tap Saddle Installations
Example pg 13

Kit Description

Retro-DWS is a tubular self-regulating heating system designed for use in 4-inch and 3-inch non-pressurized sewage and waste water drain lines, as well as other large diameter non-pressurized pipes and storm drains. The tubular heater is constructed of HDPE (high density polyethylene) and will push inside most pipes for long distances. They can also be drawn in with an electrical or plumbers fish tape.

Retro-DWS utilizes a conductive polymer tubular heater technology which provides a barrier from the fluids while providing extremely efficient freeze protection. Retro-DWS can be used as a system to prevent freezing or as a precautionary system. If the drain waste or sewer freezes, the system can be energized to begin the thawing process.

Typical Retro-DWS-GFC supplied with a 4 foot electrical cold lead. Available with Ground-Fault Protection (GFCI) or Cord-Set (CS) both in 120 volt and 240 volt.

Approvals



Usage Type W

Installation Type D USA

Table of Contents

General Information	1
Warnings	1
Kit Contents	2
Ordering Chart	2
Optional Accessories	2
Standard 4-inch Cleanout Requiring Extension	3
Standard 3-inch Cleanout Requiring Extension	5
Installing Into a Damaged 4-inch Cleanout	7
Installing Into a Damaged 3-inch Cleanout	9
Cutting in a 4-inch Wye	11
Non-Pressurised Flexible Wye Tape Saddle Installations	13

*For common installation methods including complete installation procedures and warranty refer to the standard Retro-DWS Installation Instructions. This is a conceptual installation guide for other, non-common applications. Material selection is an advisement based on information provided by others. **The customer/end user has the responsibility to make the final decision on the suitability of the component selection for their application.** The directions and additional material presented within this document is done so in good faith and is believed to be reliable and accurate.*

⚠ WARNING:

Important Safety Instructions and Rules for safe Installation and Operation

FIRE AND SHOCK HAZARD. This component is an electrical device which must be installed properly. Read and follow these rules and instructions carefully. Failure to follow them could result in serious bodily injury and/or property damage.

WHEN PERFORMING WORK OR REPAIRS ON YOUR WATER SYSTEM BE SURE TO UNPLUG YOUR HEAT-LINE SYSTEM FROM THE POWER SUPPLY.

- Check your local building, plumbing and electrical codes before installing. You must comply with their rules.

- Retro-DWS meets cCSAus codes for use in Canada and the United States.
- Before installing this product have the electrical outlet checked by an electrician to make sure it is properly installed and grounded in accordance with your local Electrical Code.
- Before installing or servicing your Retro-DWS **BE CERTAIN** that the power source is disconnected.
- Do not use extension cords.
- This product is designed to keep drains from freezing in serious climate conditions. The Retro-DWS tube may

obstruct certain materials, especially solids in the drains so a service schedule for proper maintenance is recommended. **The use of this product is at the sole discretion of the user. Heat-Line will not be liable for obstructions or blockages that may occur in some situations.**

- Never tamper with or alter the electrical apparatus associated with your Heat-Line system.
- The Retro-DWS product is **exclusively designed** to be employed in **non-pressurized** plumbing drain, waste, and sewer pipe applications. It is not designed to be installed or operated in a pressurized application.

Tools Required

- Standard screwdriver or nut driver
- Torque Wrench
- Pipe Cutting Tool for 4" and or 3" ABS
- Adjustable Wrench

Additional Materials Required

- Teflon tape or thread sealant

Kit Contents

Item	Qty	Description
A	1	Retro-DWS –Predetermined length (GFC shown)
B	1	4" Flexible pipe coupler
C	1	4" x 3" Flexible pipe reducer
D	1	4" ABS Threaded male adapter SPIG X MIPT
E	1	3" ABS Threaded male adapter SPIG X MIPT
F	1	Optional Cord-Set (CS) power connection

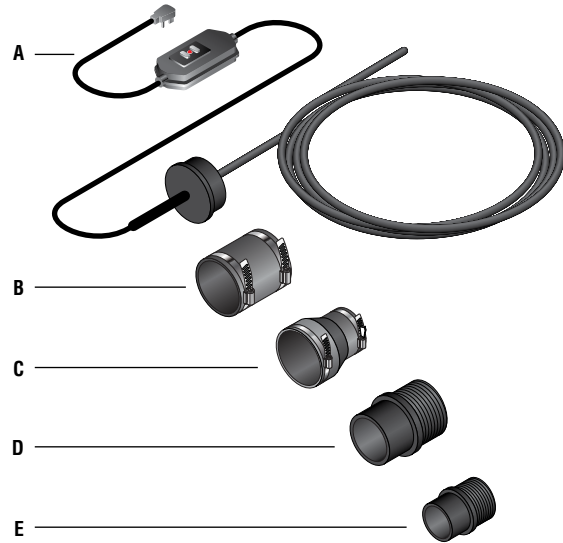

Ordering Chart

Retro-DWS | Product Code

Example: **DWS - 5 - 100 - GFC**

Product	DWS 120 volt Retro-DWS	DWS2 240 volt Retro-DWS
Wattage	5 5 Watts self-regulating heater	3* 3 watts self-regulating heater
	8* 8 watts self-regulating heater	* Special custom order only
Cord-Set Type	GFC Ground fault protected	CS Cord connected (no GFCI)
Length of System	10 to 230 feet 120 volt 5 watt systems	10 to 540 feet 240 volt 5 watt systems

Optional Accessories

- HLA-120** General purpose 120V, plug-in thermostat (for GFC models)
- GF-STAT** NEMA 4X Ground Fault Protected Thermostat 120V/240V 30 amp (for CS models)
- MA-10** GFCI/ELCI Electrical Equipment Protection Device (for CS models)
- TIMER-120P** 120V plug-in timer (for GFC models)
- TIMER-240P** 240V plug-in timer (for GFC models)
- TIMER-CS** 120/240V hard wire timer (for CS models)
- INSUL-FOIL** Aluminum reflective metalized foil bubble insulation

- FOIL-TAPE** Professional Grade All Weather Foil Tape 2.83 inches x 150 feet (72 mm x 46 m)
- INSUL-3.00** Polyethylene insulation sleeve for 3 inch ID pipe (6 feet long, 3 1/2 inch ID, 3/4 inch thick wall)
- INSUL-4.00** Polyethylene insulation sleeve for 4 inch ID pipe (6 feet long, 4 1/2 inch ID, 1 inch thick wall)
- HLP-TAPE** Black wrap tape for sealing insulation ends together 2 inches x 100 feet (50.8 mm x 3 m)
- TORQ-60** No hub torque wrench automatic release at 60 IN. LB.
- WARRANTY** Extended 10 year limited product warranty

Standard 4-inch Cleanout Requiring Extension

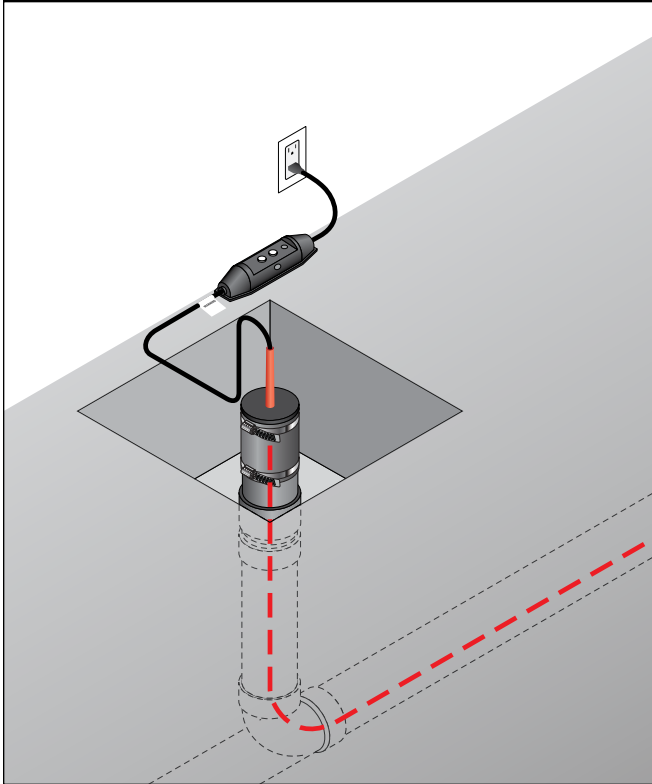

Kit Description

The Retro-DWS is supplied with all of the necessary fittings for 4-inch or 3-inch pipes at a clean out or other entry point. The Retro-DWS can be easily adapted to fit larger pipe diameters if required by using readily available, industry standard components.

For those applications where a standard 4-inch Cleanout is within a recessed access point an extension may be required to properly complete the installation of the Retro-DWS. The additional materials and tools required in this kit will allow for this type of installation to be completed.

Tools Required

- Blade screwdriver and or 5/16 Nut driver
- Torque wrench with 5/16 driver
- ABS tubing cutter up to 4.50"
- Pump pliers

Additional Materials Required

- A** Teflon Tape
- B** ABS cement
- C** 4" ABS female hub x MIPT
- D** 4" ABS pipe predetermined length for required extension

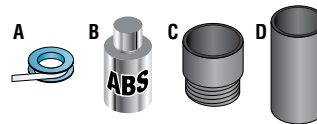

1

- Remove threaded cleanout plug.
- CAUTION:** Effluent may be present when threaded cap is removed.

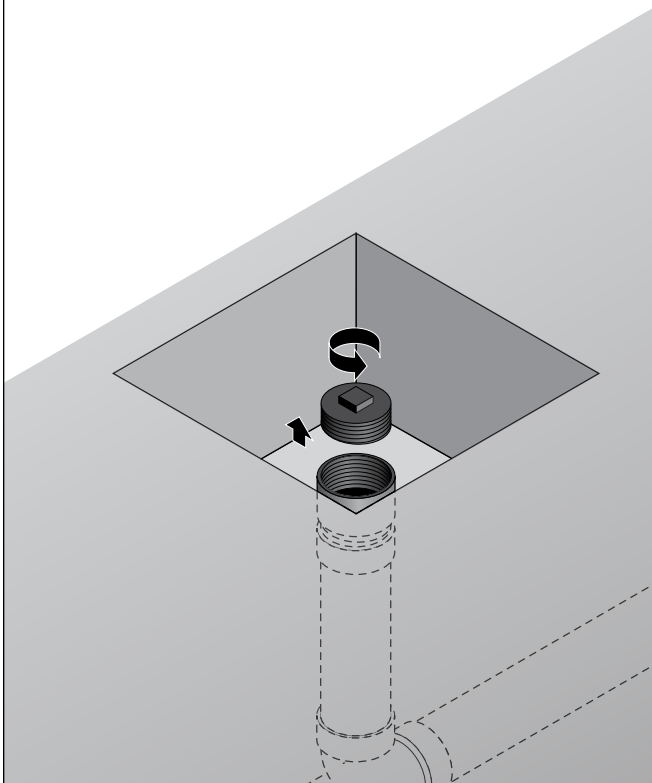

2

- Apply Teflon tape (listed as Additional Material A above) to the 4-inch ABS threaded male adapter HUB X MIPT (listed as Additional Material C above).
- Make sure to apply the Teflon tape in the direction of the threads to ensure it remains tight during threading of the fittings.
- Thread the male adapter into the clean-out female entry point and tighten with pump pliers.

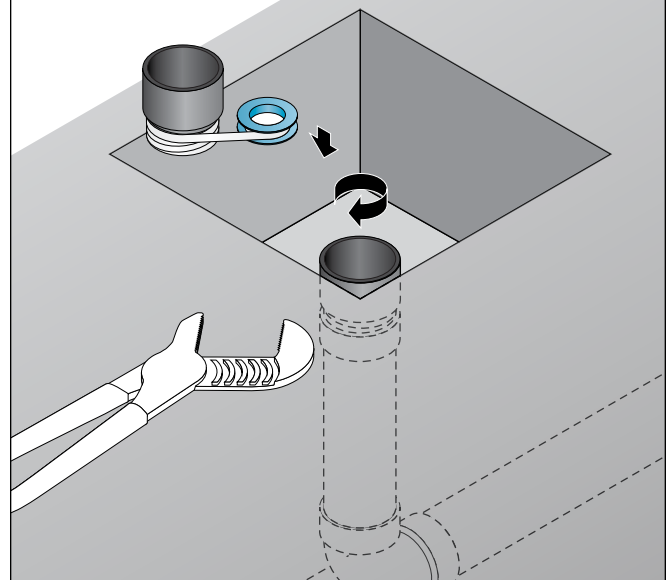

3

- Using ABS tubing cutter cut a 4-inch ABS pipe (listed as Additional Material D on Pg 3) to the appropriate length for the extension.
- Apply ABS adhesive (listed as Additional Material B on Pg 3) and insert extension pipe into the 4-inch hub.

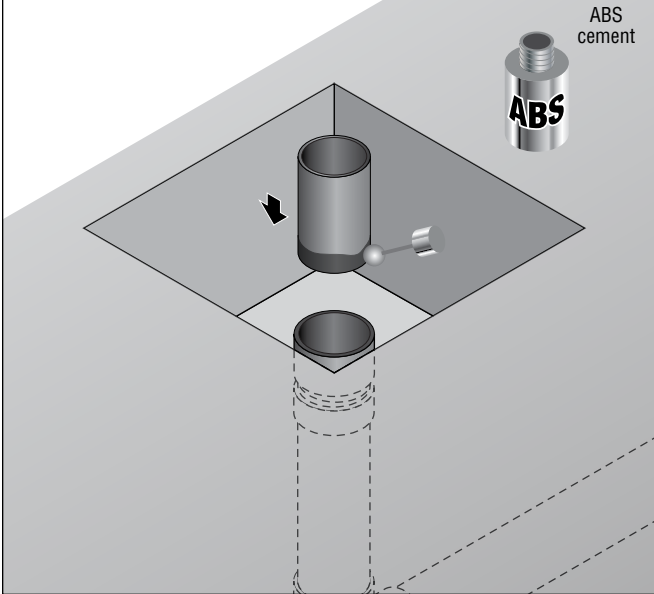

4

- Loosen the clamps on either end of the 4-inch flexible pipe coupler (shown as item B in Kit Contents on Pg 2), do not remove the clamps from their seated location on the flexible pipe coupler body.
- Slide the 4-inch flexible pipe coupler onto the now exposed spigot end of the male threaded adapter fitting and tighten the clamp to 60 inch-lb with torque wrench.

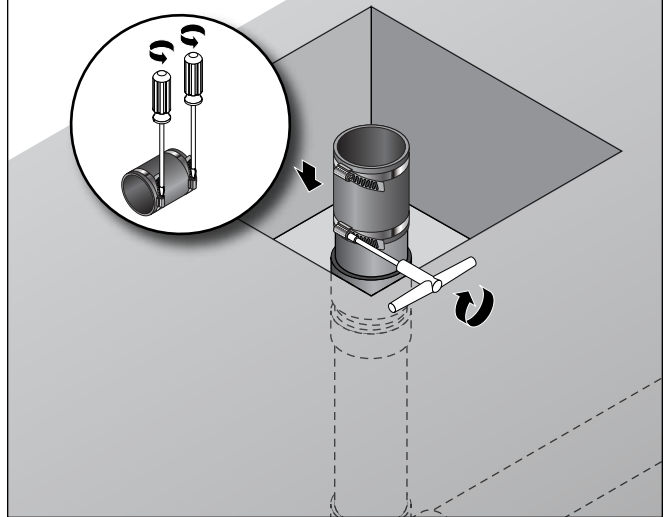

5

- Insert the Retro-DWS tubular heater into drain until the bushing interfaces into the coupling.

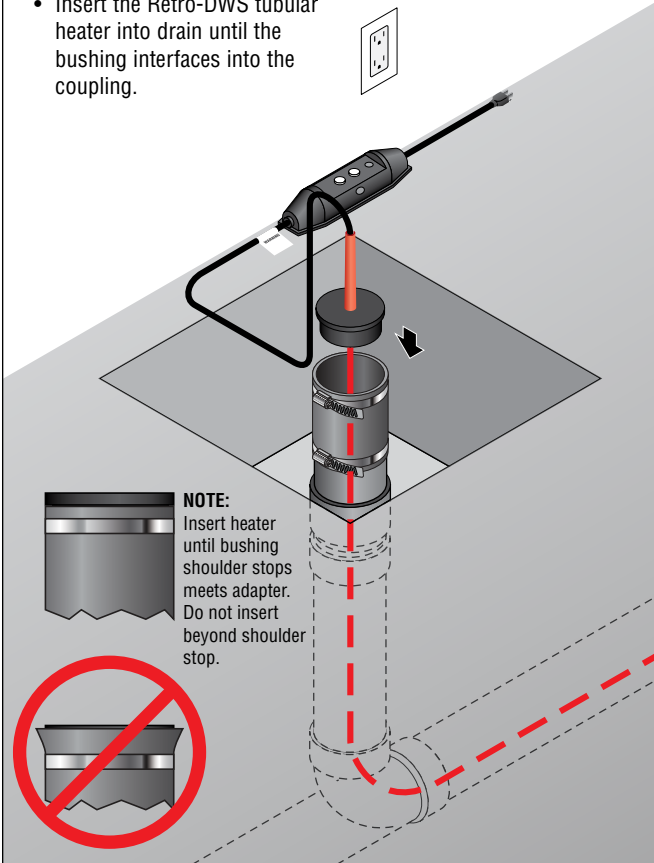

6

- Using torque wrench tighten clamp around Retro-DWS to 60 inch-lb.
- In accordance with standard industry practices test the integrity of the seal.
- Plug in heater and Test/Reset GFCI located in cord set.

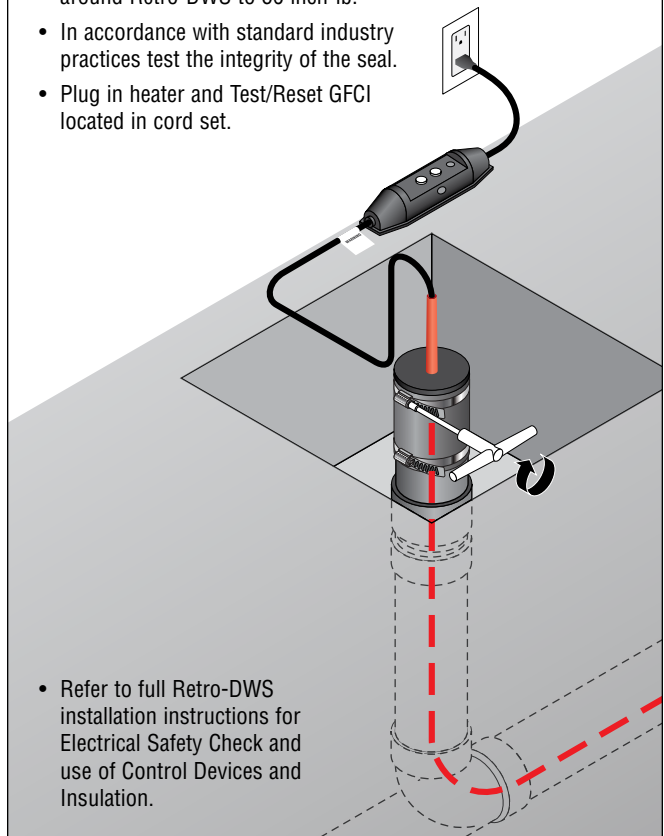

- Refer to full Retro-DWS installation instructions for Electrical Safety Check and use of Control Devices and Insulation.

Standard 3-inch Cleanout Requiring Extension

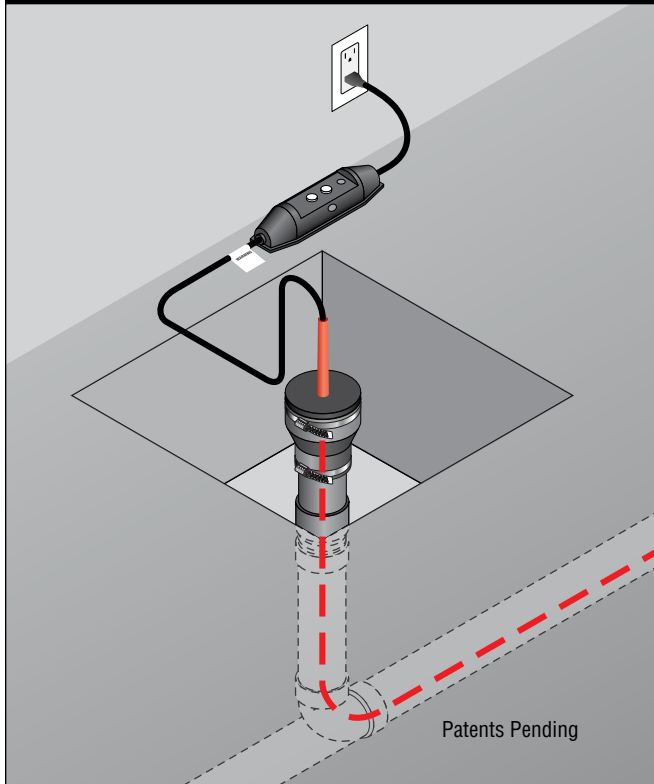

Kit Description

The Retro-DWS is supplied with all of the necessary fittings for 4-inch or 3-inch pipes at a clean out or other entry point. The Retro-DWS can be easily adapted to fit larger pipe diameters if required by using readily available, industry standard components.

For those applications where a standard 3-inch cleanout is within a recessed access point an extension may be required to properly complete the installation of the Retro-DWS. The additional materials and tools required in this kit will allow for this type of installation to be completed.

Tools Required

- Blade screwdriver and or 5/16 Nut driver
- Torque wrench with 5/16 driver
- ABS tubing cutter up to 3.5"
- Pump pliers

Additional Materials Required

- A** Teflon Tape
- B** ABS cement
- C** 3" ABS female hub x MIPT
- D** 3" ABS pipe predetermined length for required extension

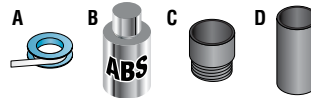

1

- Remove threaded cleanout plug.
- CAUTION:** Effluent may be present when threaded cap is removed.

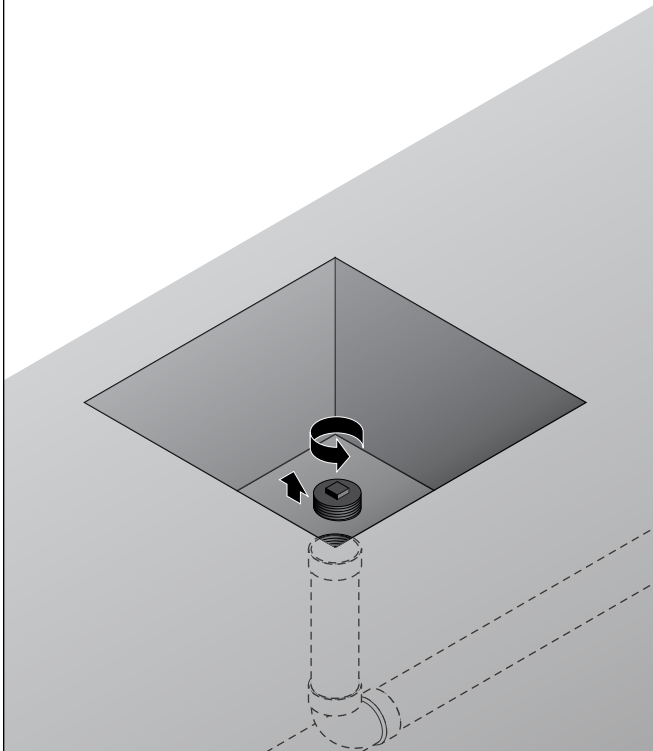

2

- Apply Teflon tape (listed as Additional Material A above) to the 3-inch ABS threaded male adapter HUB X MIPT (listed as Additional Material C above).
- Make sure to apply the Teflon tape in the direction of the threads to ensure it remains tight during threading of the fittings.
- Thread the male adapter into the clean-out female entry point and tighten with pump pliers.

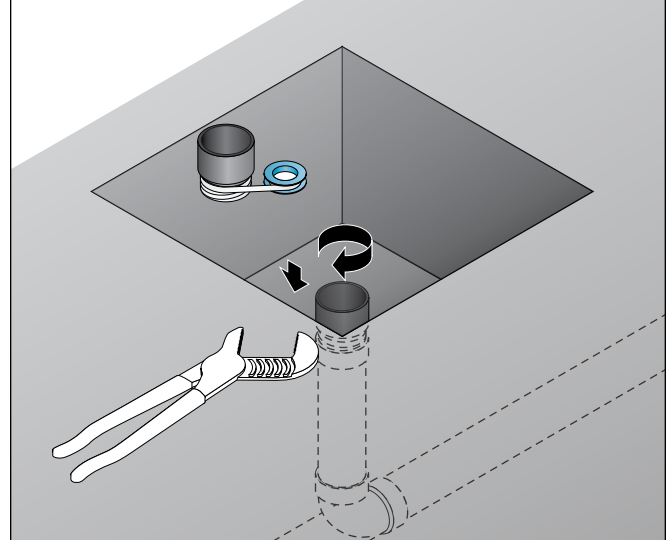

3

- Using ABS tubing cutter cut a 3-inch ABS pipe (listed as Additional Material D on Pg 5) to the appropriate length for the extension.
- Apply ABS adhesive (listed as Additional Material B on Pg 5) and insert extension pipe into the 3-inch hub.

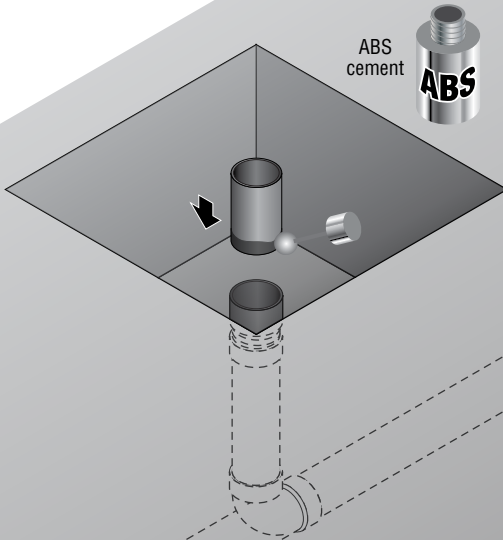

4

- Loosen the clamps on either end of the 4" x 3" flexible pipe reducer (shown as item C in Kit Contents on Pg 2), do not remove the clamps from their seated location on the flexible pipe coupler body.
- Slide the 3-inch adapter side of flexible pipe reducer onto the now exposed spigot end of the male threaded adapter fitting and tighten the clamp to 60 inch-lb with torque wrench.

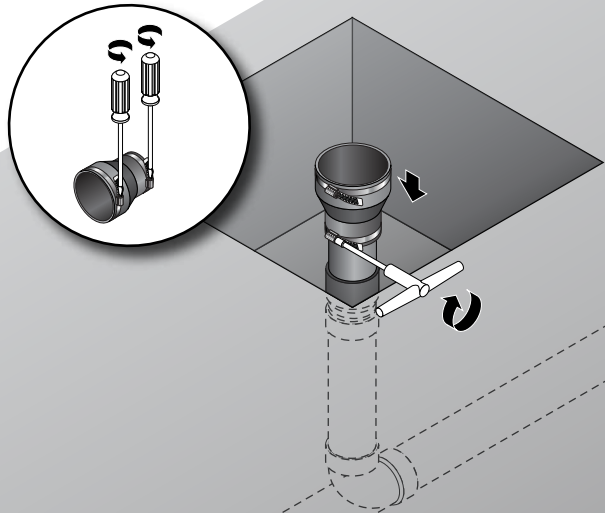

5

- Insert the Retro-DWS tubular heater into drain until the bushing interfaces into the coupling.

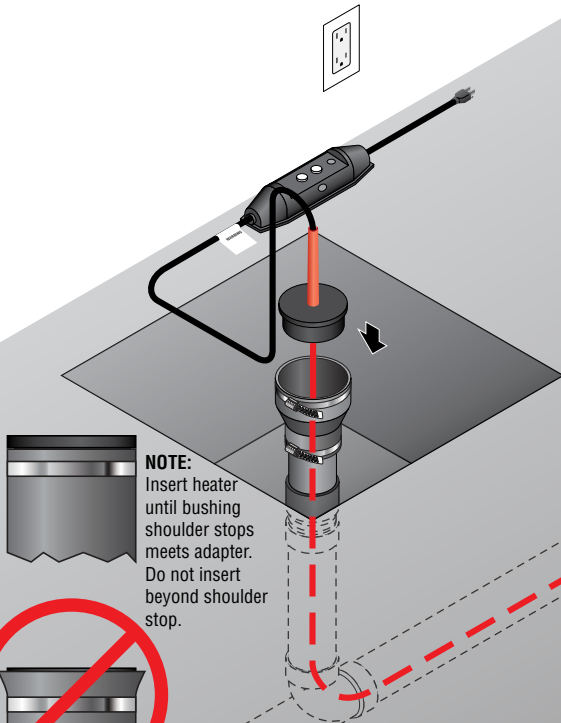

6

- Using torque wrench tighten clamp around Retro-DWS to 60 inch-lb.
- In accordance with standard industry practices test the integrity of the seal.
- Plug in heater and Test/Reset GFCI located in cord set.

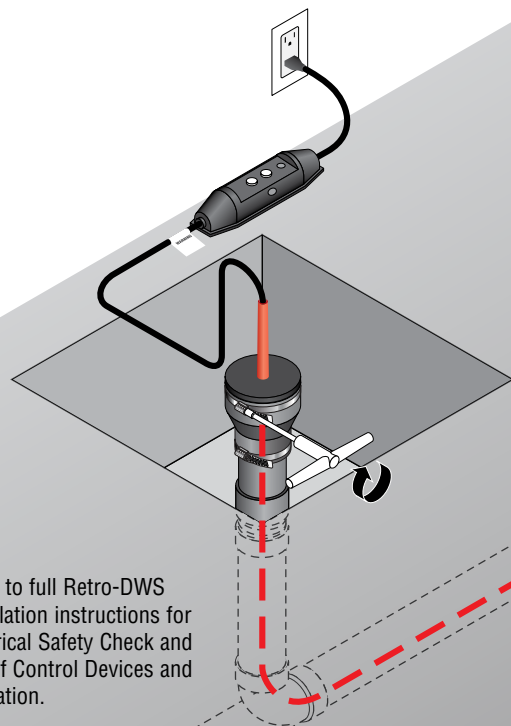

- Refer to full Retro-DWS installation instructions for Electrical Safety Check and use of Control Devices and Insulation.

Installing Into a Damaged 4-inch Cleanout

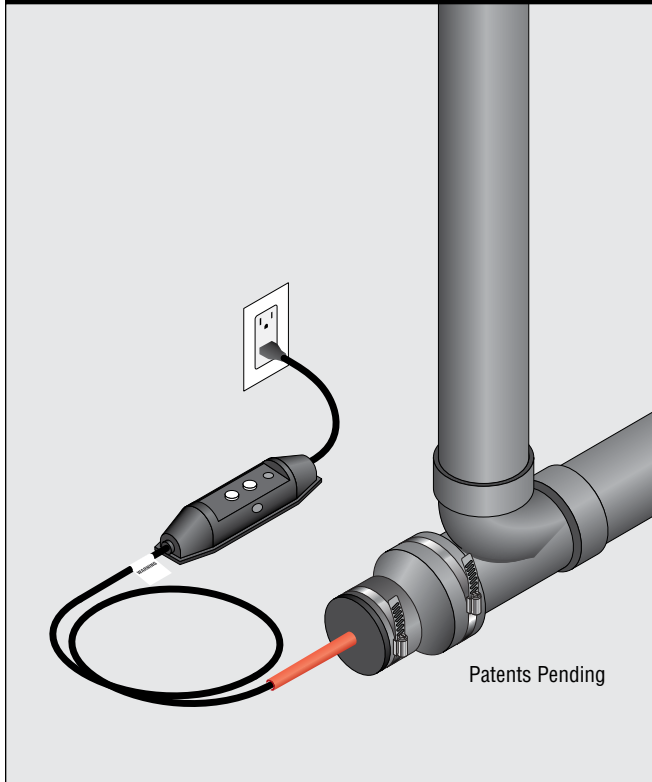

Kit Description

The Retro-DWS is supplied with all of the necessary fittings for 4-inch or 3-inch pipes at a clean out or other entry point. The Retro-DWS can be easily adapted to fit larger pipe diameters if required by using readily available, industry standard components.

For those applications where a standard 4-inch cleanout is damaged and cannot easily be removed a cutting tool and or hacksaw may be employed to remove the damaged cleanout and complete a proper Retro-DWS installation. The additional materials and tools required in this kit will allow for this type of installation to be completed.

Tools Required

- Blade screwdriver and or 5/16 Nut driver
- Torque wrench with 5/16 driver
- ABS tubing cutter up to 4.5" or Hacksaw
- Pump pliers

Additional Materials Required

- Fernco 5.2" x 4.5" flexible reducing coupling or equivalent

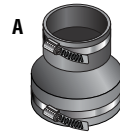

1

- Cut back the cleanout adapter to the socket of the sanitary tee with a ABS tubing cutter and or Hacksaw.

CAUTION: Effluent may be present when cleanout is cut back.

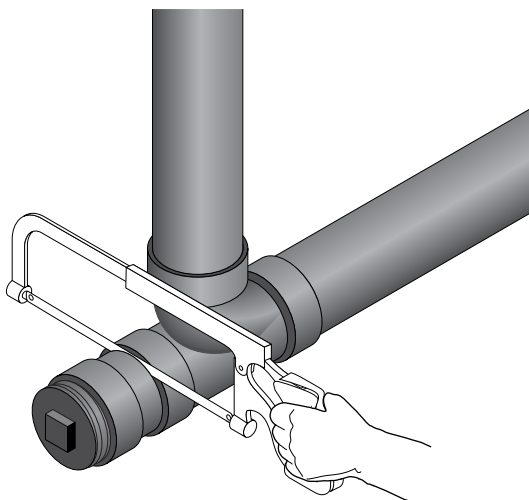

2

- Loosen the clamps on either end of the flexible pipe reducer (listed as Additional Material A above), do not remove the clamps from their seated location on the flexible pipe reducer body.
- Slide the larger adapter side of flexible pipe reducer onto and over top of the now exposed opening of the 4-inch sanitary tee assembly.
- Tighten the clamp on the 4-inch sanitary tee to 60 inch-lb with torque wrench.

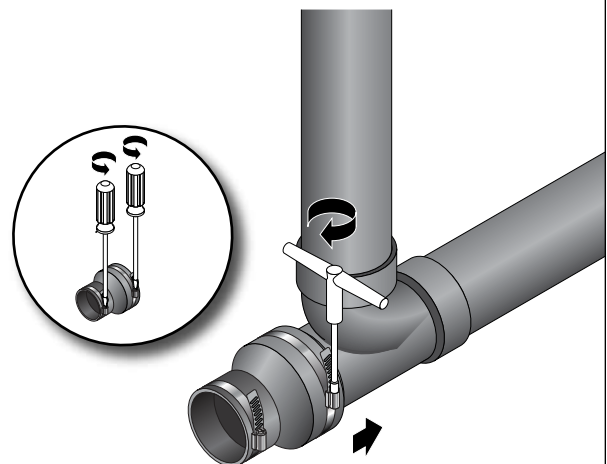

3

- Insert the Retro-DWS tubular heater into drain until the bushing interfaces into the coupling.

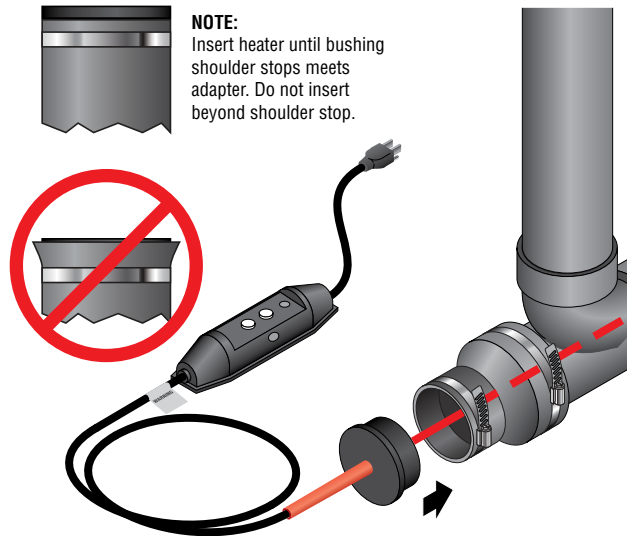

4

- Using torque wrench tighten clamp around Retro-DWS to 60 inch-lb.

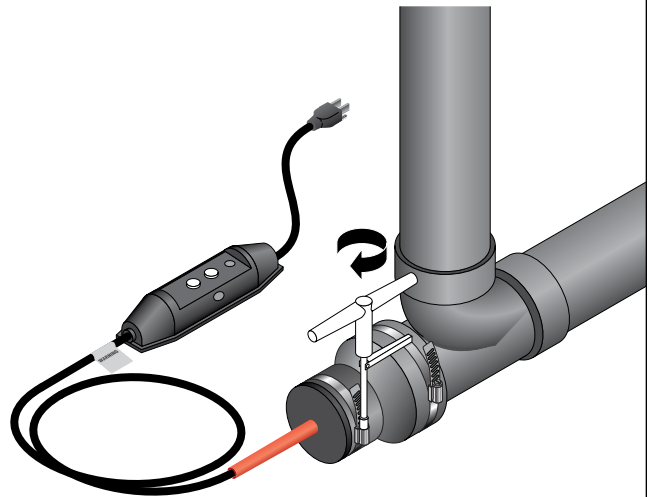

5

- In accordance with standard industry practices test the integrity of the seal.
- Plug in heater and Test/Reset GFCI located in cord set.

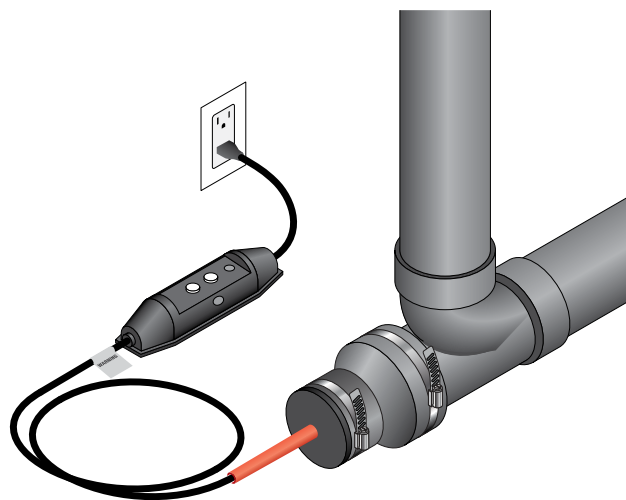

- Refer to full Retro-DWS installation instructions for Electrical Safety Check and use of Control Devices and Insulation.

Installing Into a Damaged 3-inch Cleanout

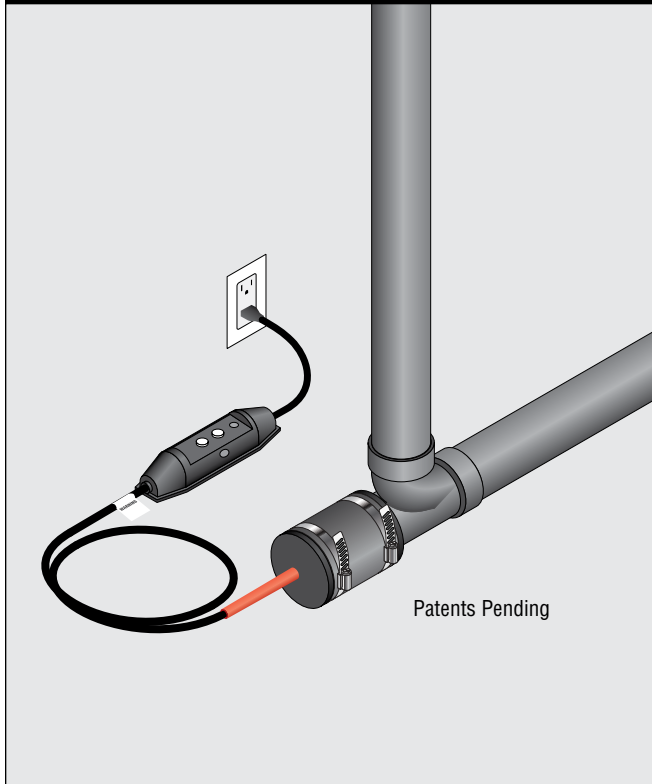

Kit Description

The Retro-DWS is supplied with all of the necessary fittings for 4-inch or 3-inch pipes at a clean out or other entry point. The Retro-DWS can be easily adapted to fit larger pipe diameters if required by using readily available, industry standard components.

For those applications where a standard 3-inch cleanout is damaged and cannot easily be removed a cutting tool and or hacksaw may be employed to remove the damaged cleanout and complete a proper Retro-DWS installation. The additional materials and tools required in this kit will allow for this type of installation to be completed.

Tools Required

- Blade screwdriver and or 5/16 nut driver
- Torque wrench with 5/16 driver
- ABS tubing cutter up to 3.5" or hacksaw

Additional Materials Required

- Fernco 4.380 – 4.000R reducing bushing or equivalent



1

- Cut back the cleanout adapter to the socket of the sanitary tee with a ABS tubing cutter and or hacksaw.

CAUTION: Effluent may be present when cleanout is cut back.

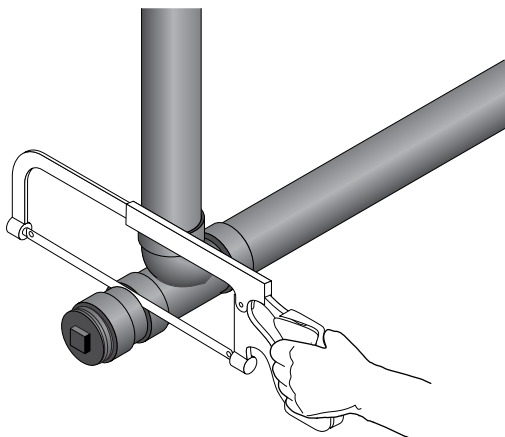

2

- Install reducing bushing (listed as Additional Material A above) according to manufacturers installation procedures.

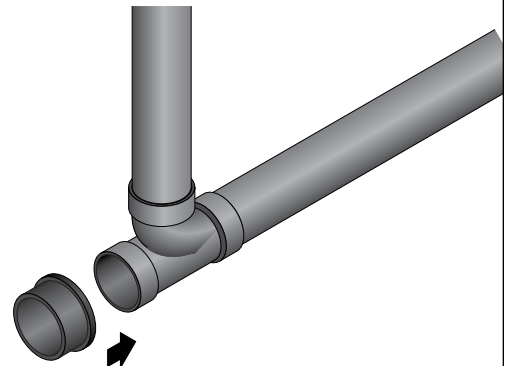

3

- Loosen the clamps on either end of the 4-inch flexible pipe coupler (shown as item B in Kit Contents on Pg 2), do not remove the clamps from their seated location on the flexible pipe reducer body.
- Slide the flexible pipe coupler over the 4.380 – 4.000 reducing bushing.
- Using torque wrench tighten clamp \ to 60 inch-lb.

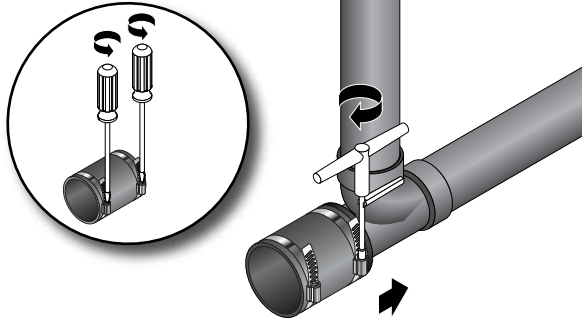

4

- Insert the Retro-DWS tubular heater into drain until the bushing interfaces into the coupling.



NOTE:
Insert heater until bushing shoulder stops meets adapter. Do not insert beyond shoulder stop.

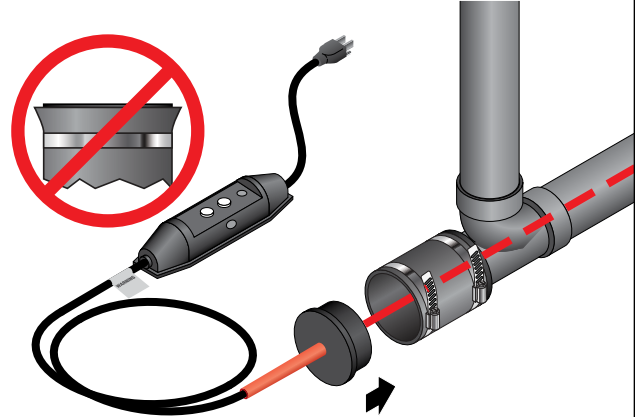

5

- Using torque wrench tighten clamp around Retro-DWS to 60 inch-lb.

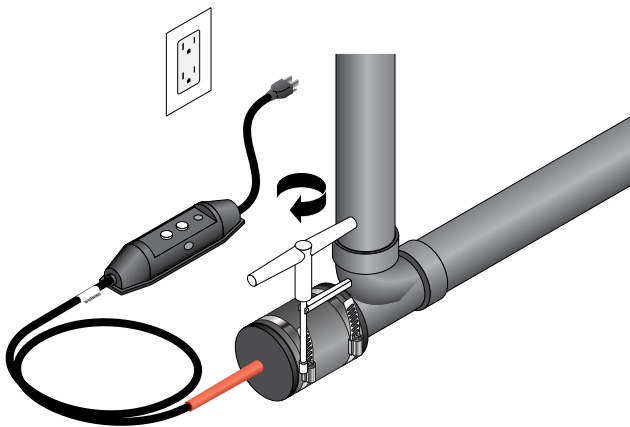

6

- In accordance with standard industry practices test the integrity of the seal.
- Plug in heater and Test/Reset GFCI located in cord set.

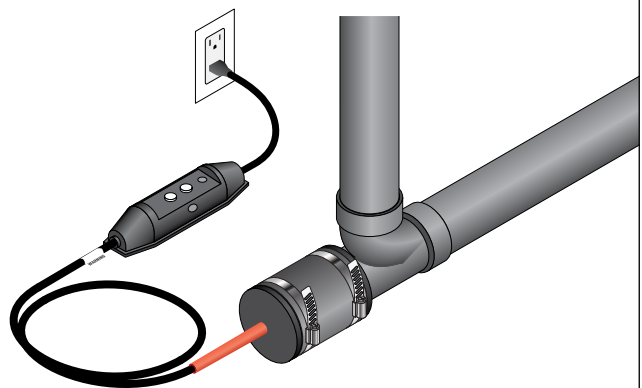

- Refer to full Retro-DWS installation instructions for Electrical Safety Check and use of Control Devices and Insulation.

Cutting in a 4-inch Wye

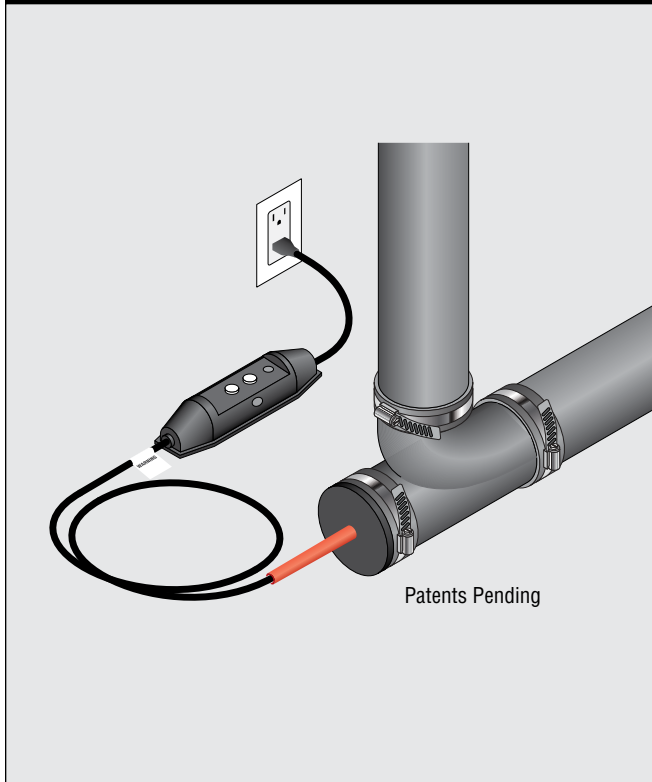

Kit Description

The Retro-DWS is supplied with all of the necessary fittings for 4-inch or 3-inch pipes at a clean out or other entry point. The Retro-DWS can be easily adapted to fit larger pipe diameters if required by using readily available, industry standard components.

For those applications where a standard 4" ABS pipe joint may require the installation of a tee to accept the Retro-DWS system a cutting tool and or hacksaw may be employed to complete the proper installation. The additional materials and tools required in this kit will allow for this type of installation to be completed.

Tools Required

- Blade screwdriver and or 5/16 Nut driver
- Torque wrench with 5/16 driver
- ABS tubing cutter up to 4.5" or Hacksaw

Additional Materials Required

- Fernco QT-400 Flexible Tee Connector 4" X 4" X 4" or equivalent

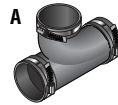

1

- Elbow exiting the building will be cut out.

CAUTION: Effluent may be present when cleanout is cut back.

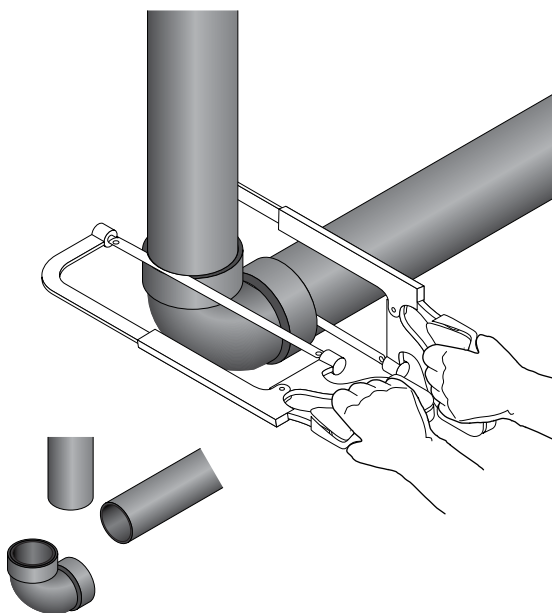

2

- Install flexible tee connector (listed as Additional Material A above) according to manufacturers installation procedures.

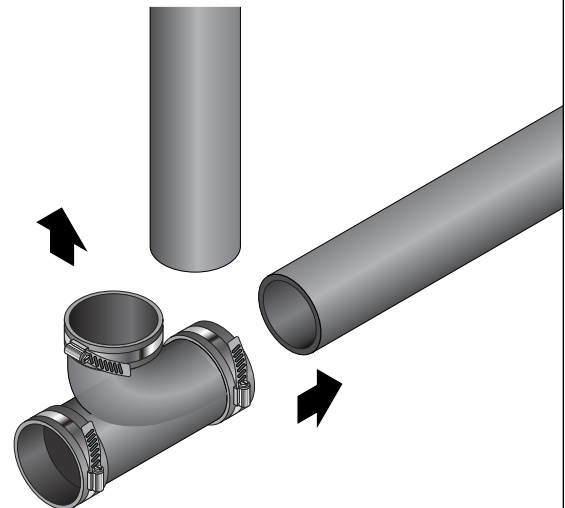

3

- Install flexible tee according to manufactures installation procedures.

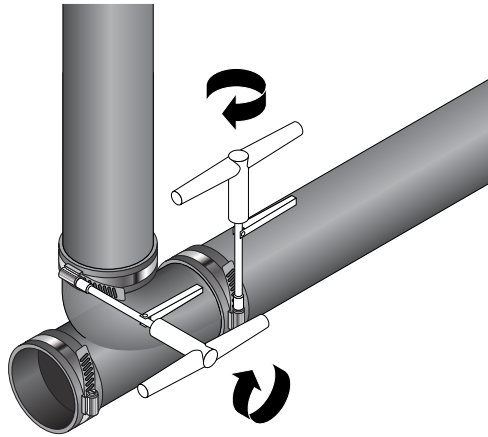

4

- Insert the Retro-DWS tubular heater into drain through the open end of the flexible tee until the bushing interfaces into the tee.



NOTE:
Insert heater until bushing shoulder stops meets adapter. Do not insert beyond shoulder stop.

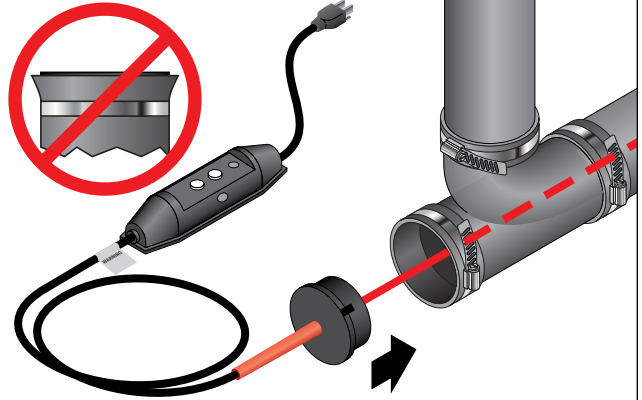

5

- Tighten clamps to 60 inch pounds.

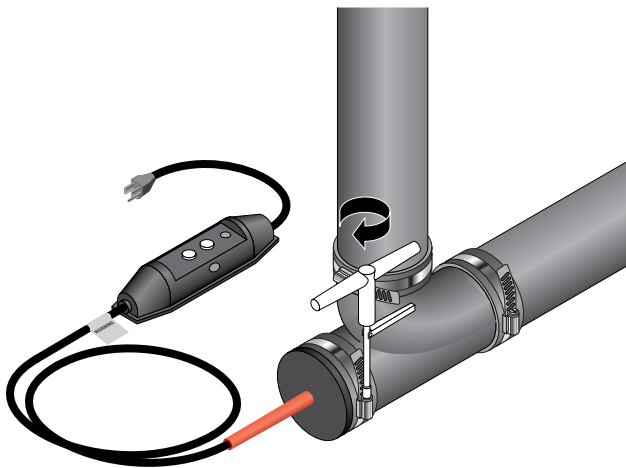

6

- Plug in heater and Test/Reset GFCI located in cord set.

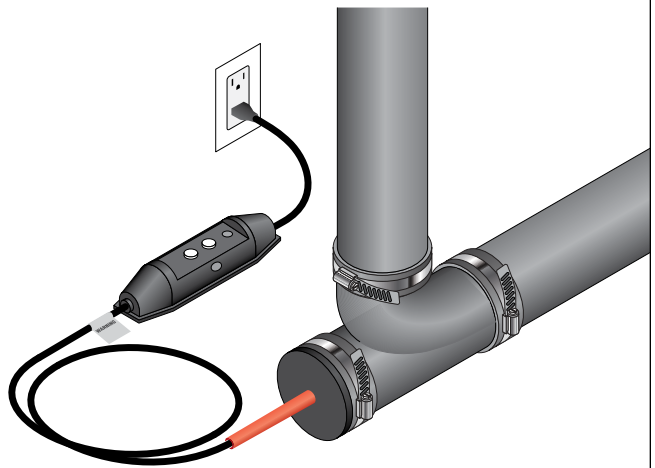

- Refer to full Retro-DWS installation instructions for Electrical Safety Check and use of Control Devices and Insulation.

Non-Pressurised Flexible Wye Tap Saddle Installations

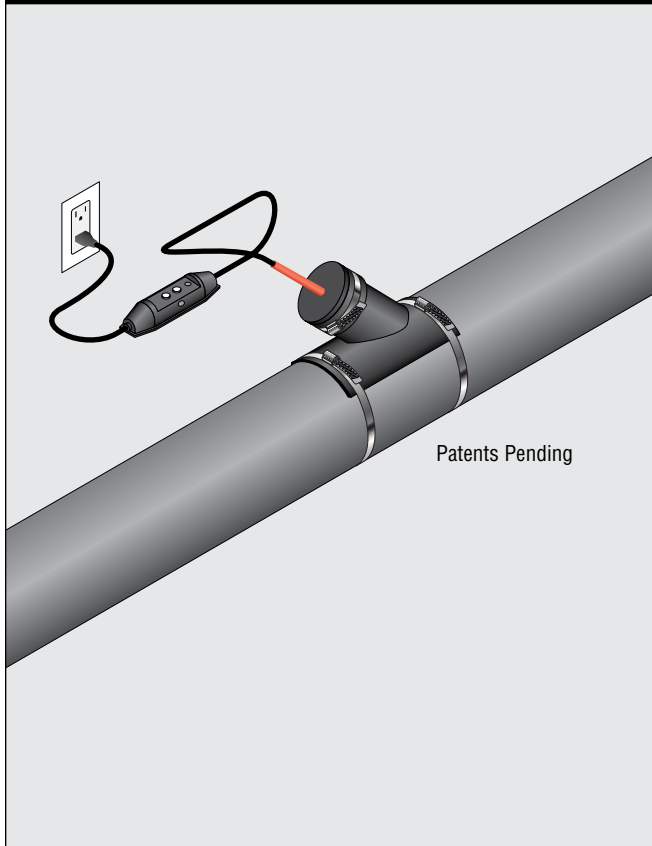

Kit Description

The Retro-DWS is supplied with all of the necessary fittings for 4-inch or 3-inch pipes at a clean out or other entry point. The Retro-DWS can be easily adapted to fit larger pipe diameters if required by using readily available, industry standard components.

For those applications where a non-metallic pipe diameter of 6"–15" requires internal freeze protection from a Retro-DWS system a specialized flexible wye tap saddle with a 4" opening can be installed to accept the Retro-DWS system. The additional materials and tools required in this kit will allow for this type of installation to be completed.

Tools Required

- Blade screwdriver and or 5/16 Nut driver
- 5" coring bit or hole saw
- De-burring tool
- Torque wrench with 5/16 driver.

Additional Materials Required

- Fernco Flexible Wye Tap Saddle (TSW-4) or equivalent

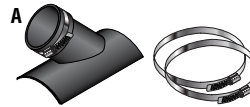

1

- Install flexible wye tap saddle (listed as Additional Material A above) according to manufacturer's specifications.

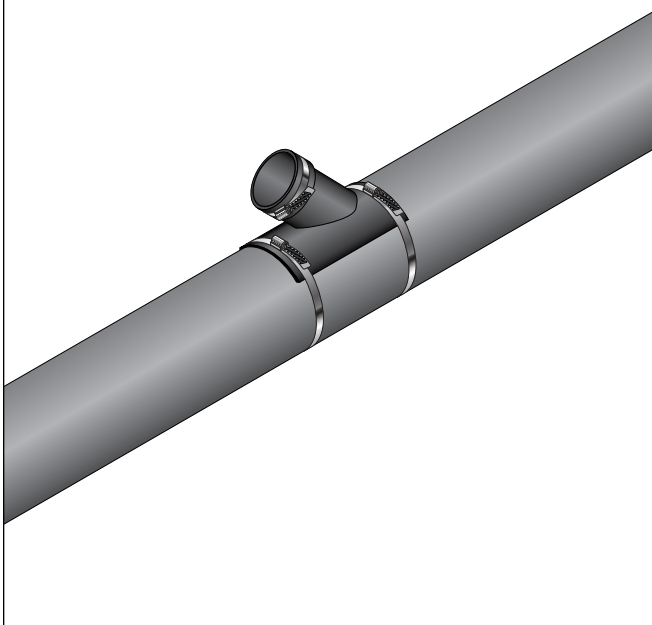

2

- Install the Retro-DWS tubular heater into the flexible pipe saddle until the bushing interfaces into the saddle opening.



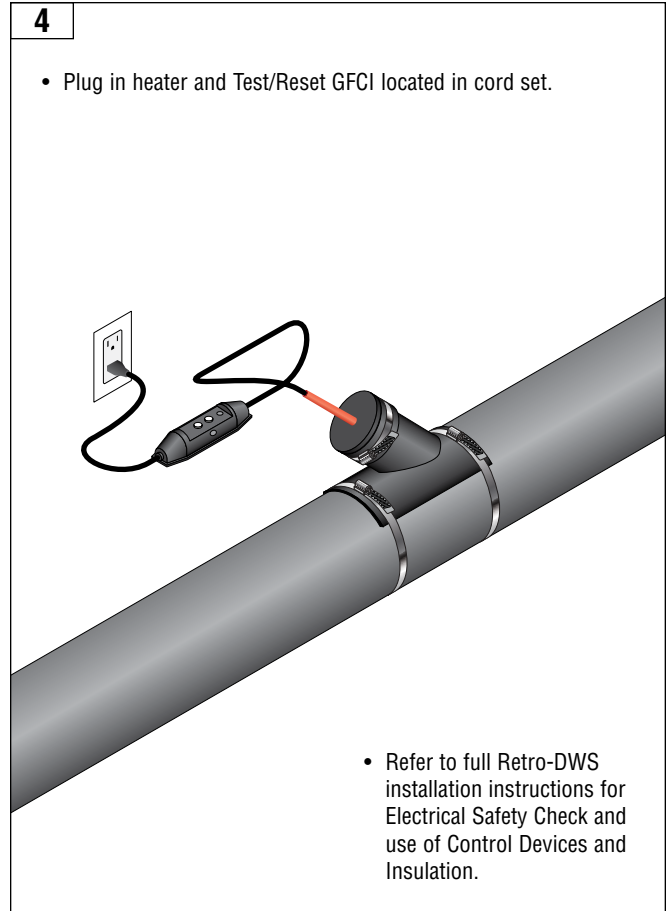
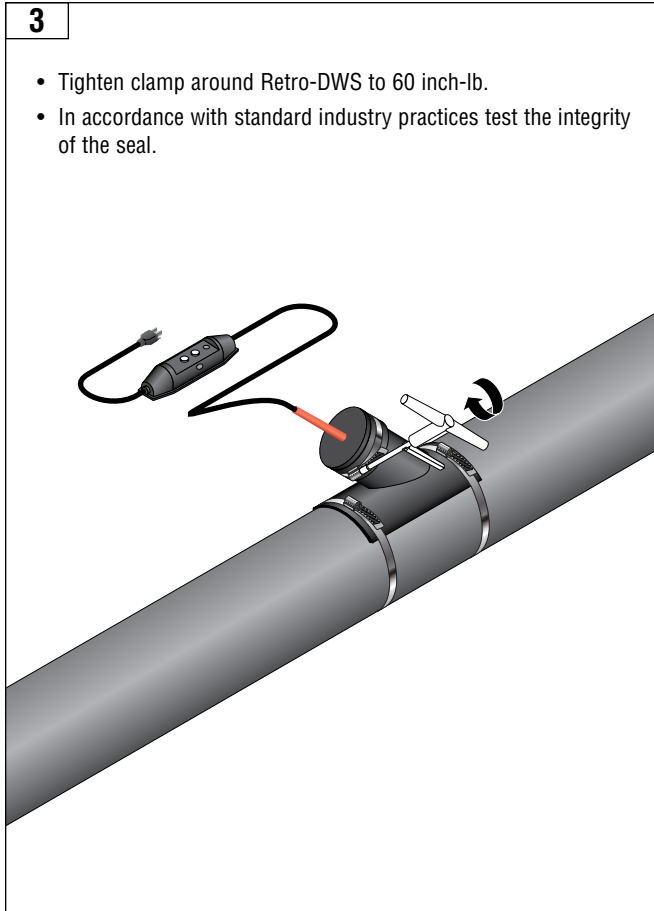

Heat-Line Freeze Protection Systems

1095 Green Lake Road
 Algonquin Highlands, ON Canada
 KOM 1J1
 Tel: (705) 754-4545
 (800) 584-4944
 Fax: (705) 754-4567
 info@heatline.com
 www.heatline.com

Heat-Line and Retro-DWS are registered trademarks of Heat-Line Corporation.
 Fernco is a registered trademark of Fernco Connectors Ltd.

Important: All information, including illustrations, is believed to be reliable. Users, however, should independently evaluate the suitability of each product for their particular application. Heat-Line a Division of Christopher MacLean Ltd. makes no warranties as to the accuracy or completeness of the information, and disclaims any liability regarding its use. Heat-Line's only obligations are those in the Heat-Line Standard Terms and Conditions of Sale for this product, and in no case will Heat-Line be liable for any incidental, indirect, or consequential damages arising from the sale, resale, use, or misuse of the product. Specifications are subject to change without notice. In addition, Heat-Line reserves the right to make changes—without notification to Buyer—to processing or materials that do not affect compliance with any applicable specification.